

# Wind Design

Luis Arribas - CIEMAT



1. Selection of the Configuration of Renewable Energy Diesel Power System (REDPS) to be designed
2. Description of the Design Process
3. Specification, testing and commissioning, and O&M

# 1.- Selection of the Configuration of REDPS to be designed: Diesel dominated

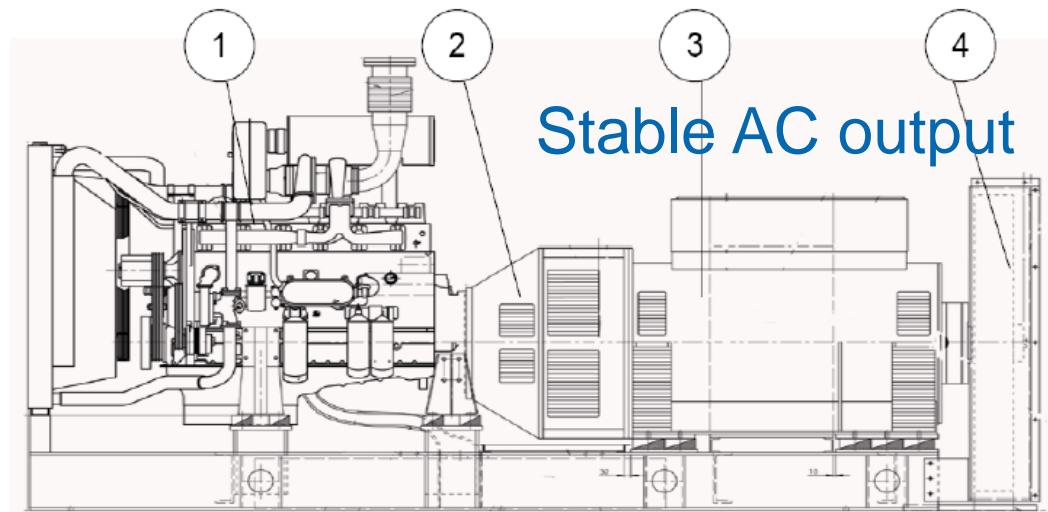

1. Diesel engine
2. Clutch (optional)
3. Synchronous machine
4. Flywheel (optional)

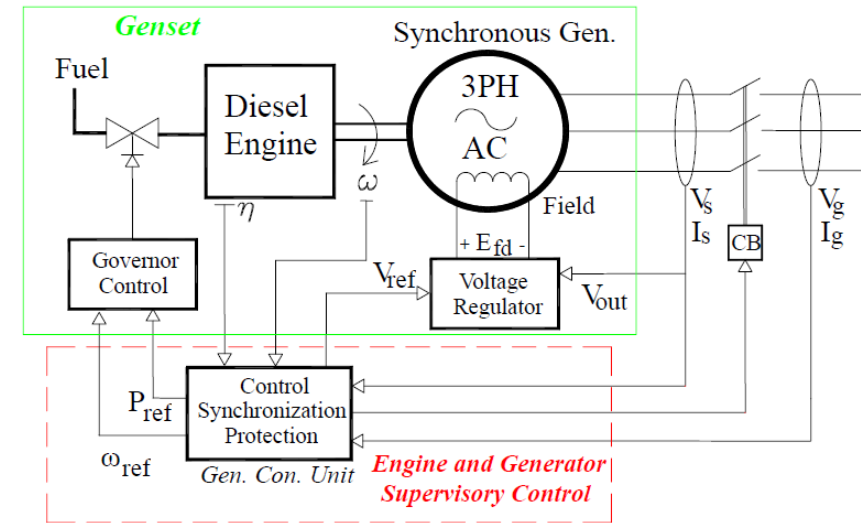

## Limitations for flexibility:

- $0 < P_D < P_{Nom}$
- Ramps (Power / minute)
- Minimum load (% full load)
- Hot start-up time
- Minimum runtime

# 1.- Selection of the Configuration of REDPS to be designed: Diesel dominated

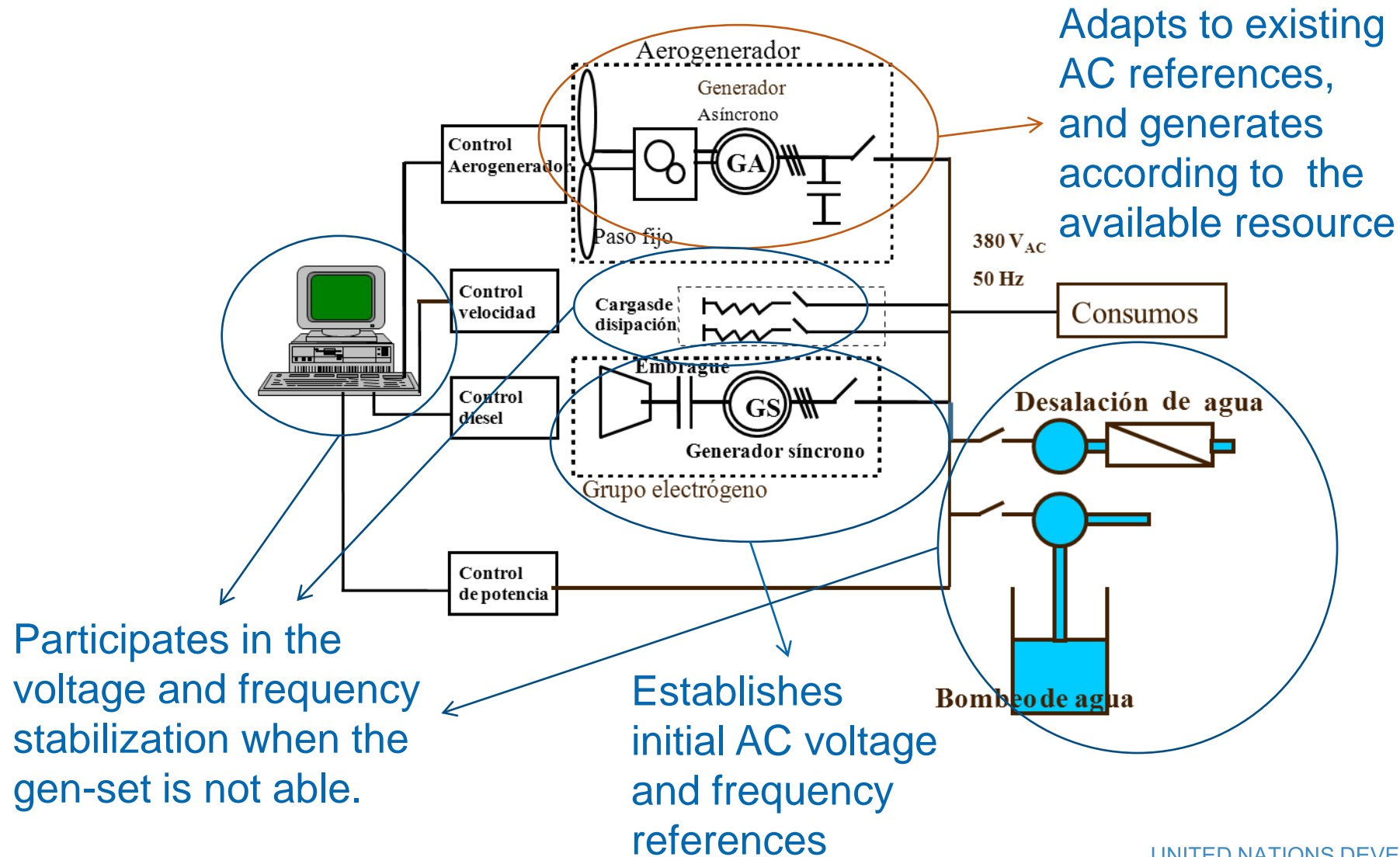

# 1.- Selection of the Configuration of REDPS to be designed: **Diesel dominated**



## Wind-diesel systems

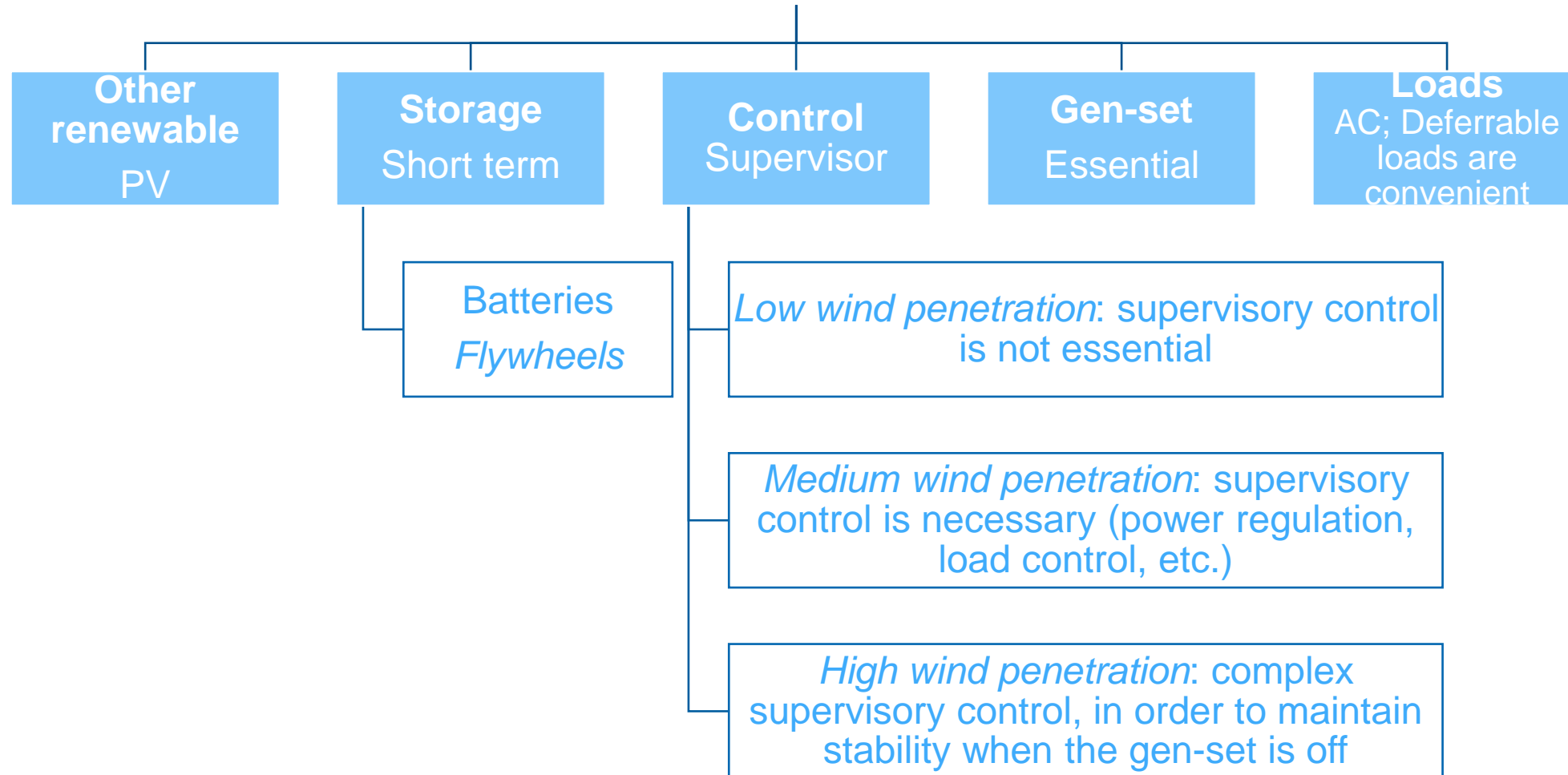

# 1.- Selection of the Configuration of REDPS to be designed: **Inverter dominated**



Limitations for flexibility:

- Nominal power
- RE power at the AC side
- Time (autonomy, in hours)

# 1.- Selection of the Configuration of REDPS to be designed: **Inverter dominated**

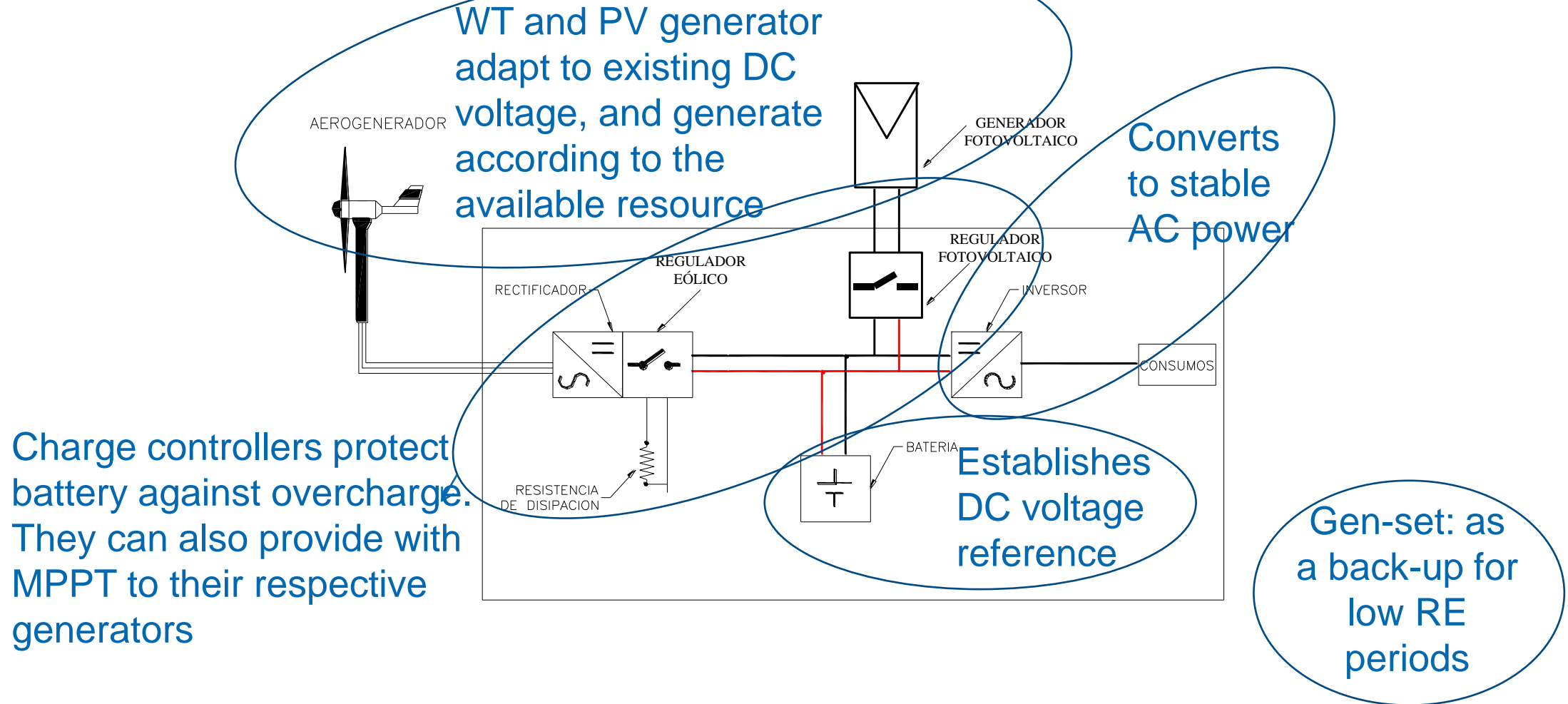

# 1.- Selection of the Configuration of REDPS to be designed: **Inverter dominated**



## Wind-battery systems

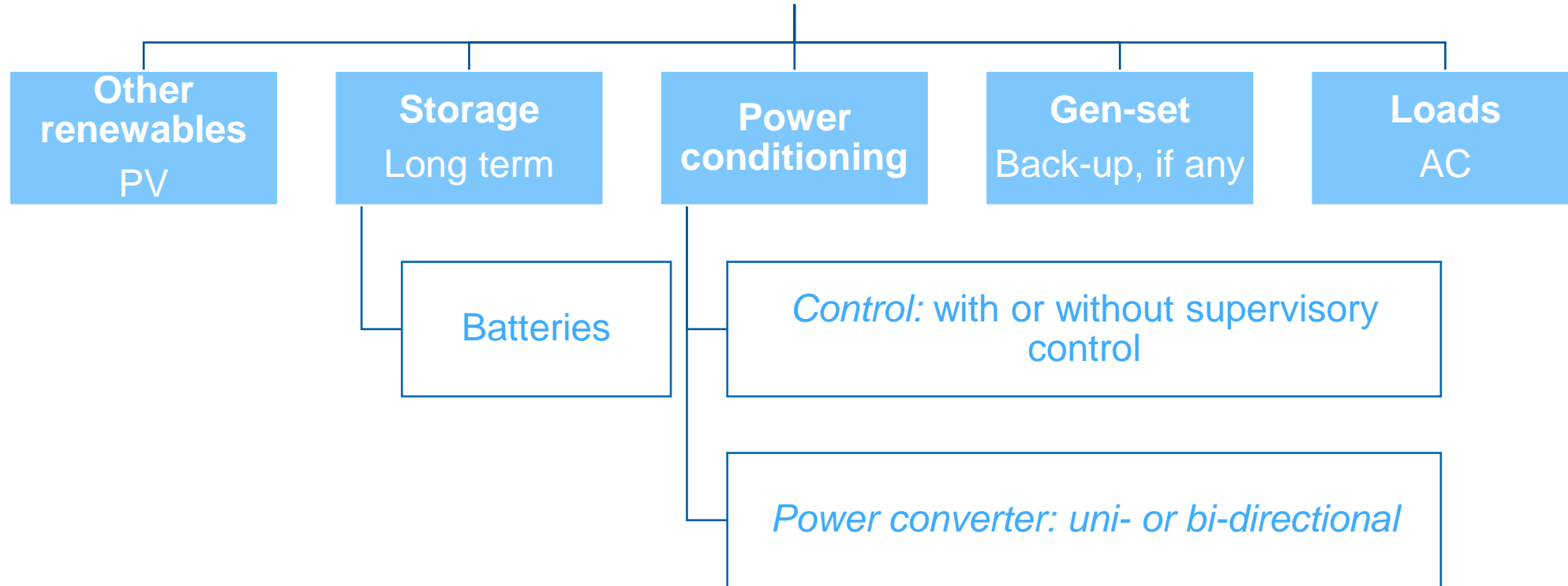

# 2.- Description of the Design Process

- a. Data collection
- b. Sizing study
- c. Implementation guidelines

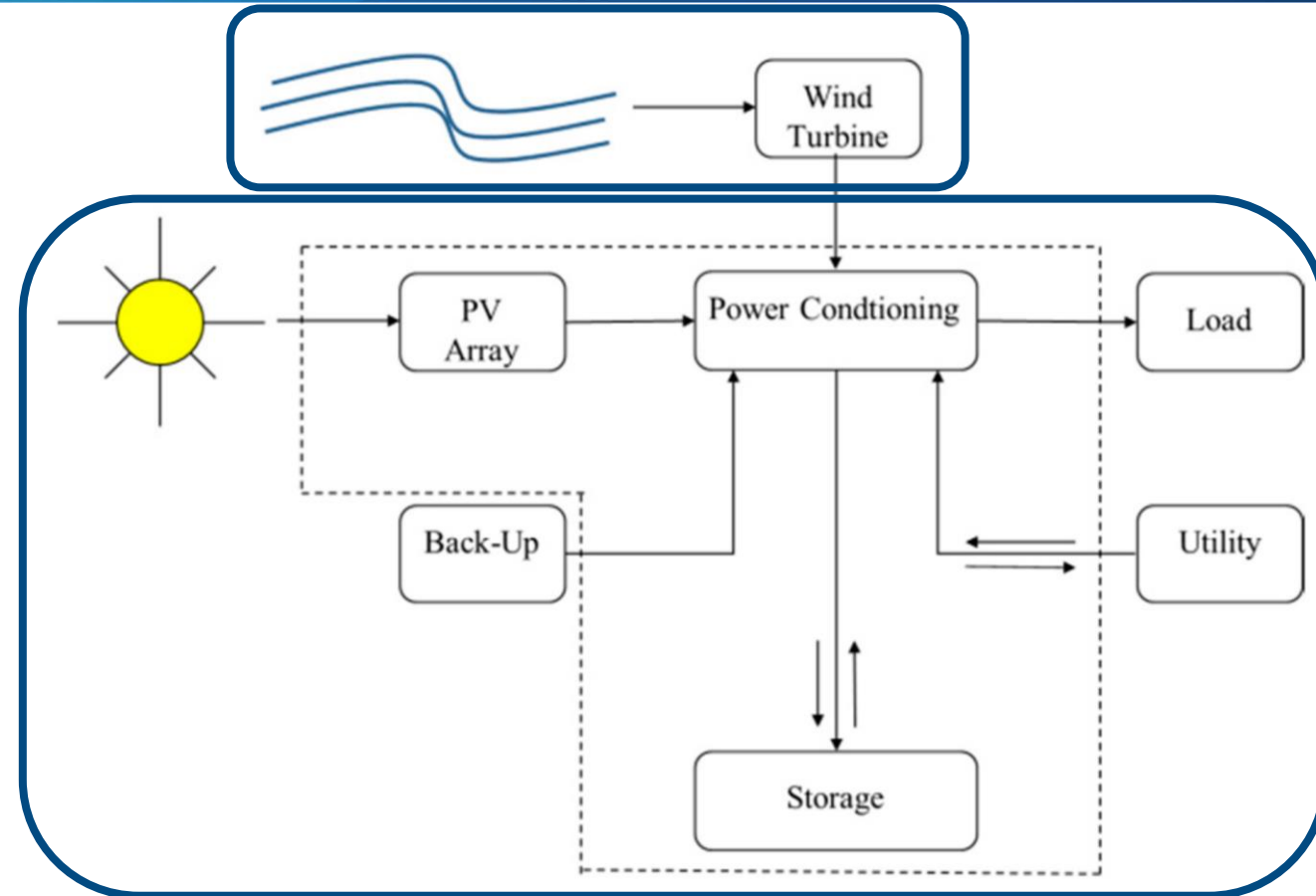

Arribas, L.; Bitenc, N.; Benech, A. Taking into Consideration the Inclusion of Wind Generation in Hybrid Microgrids: A Methodology and a Case Study. *Energies* 2021, 14, 4082. <https://doi.org/10.3390/en14144082>

## 2.- Description of the Design Process

### a) Data collection: **i.- Information request**



#### **Site description**

- Pictures
- Topographic
- Roughness
- Altitude
- Obstacles
- Coordinates

- Target buildings
- Permission
- Soil conditions
- Exact position
- Building heights
- Noise research

## 2.- Description of the Design Process

### a) Data collection: **ii.- SWT wind resource assessment**



- Sources of wind data
- Measuring campaign
- Data analysis
- Selection of the site: analysis of the influence of obstacles

## 2.- Description of the Design Process

### a) Data collection: **ii.- SWT wind resource assessment**



## Sources of wind data

### Sought data:

- Temporal/Spatial resolution: 60 minutes or less / the lowest
- Duration: one year at least
- Good quality data; well correlated to the site's data

### Reviewed Sources

- [www.worldweatheronline.com](http://www.worldweatheronline.com) (suggested by EEG)
  - One of them promising
- National Oceanic and Atmospheric Administration (NOAA)
  - No wind speed / direction measurements available in the weather stations at Lebanon
- Lebanon Weather Stations
  - One of them promising
- Lebanese Agricultural Research Institute (LARI)
  - Daily data
- [The National Wind Atlas of Lebanon](#)

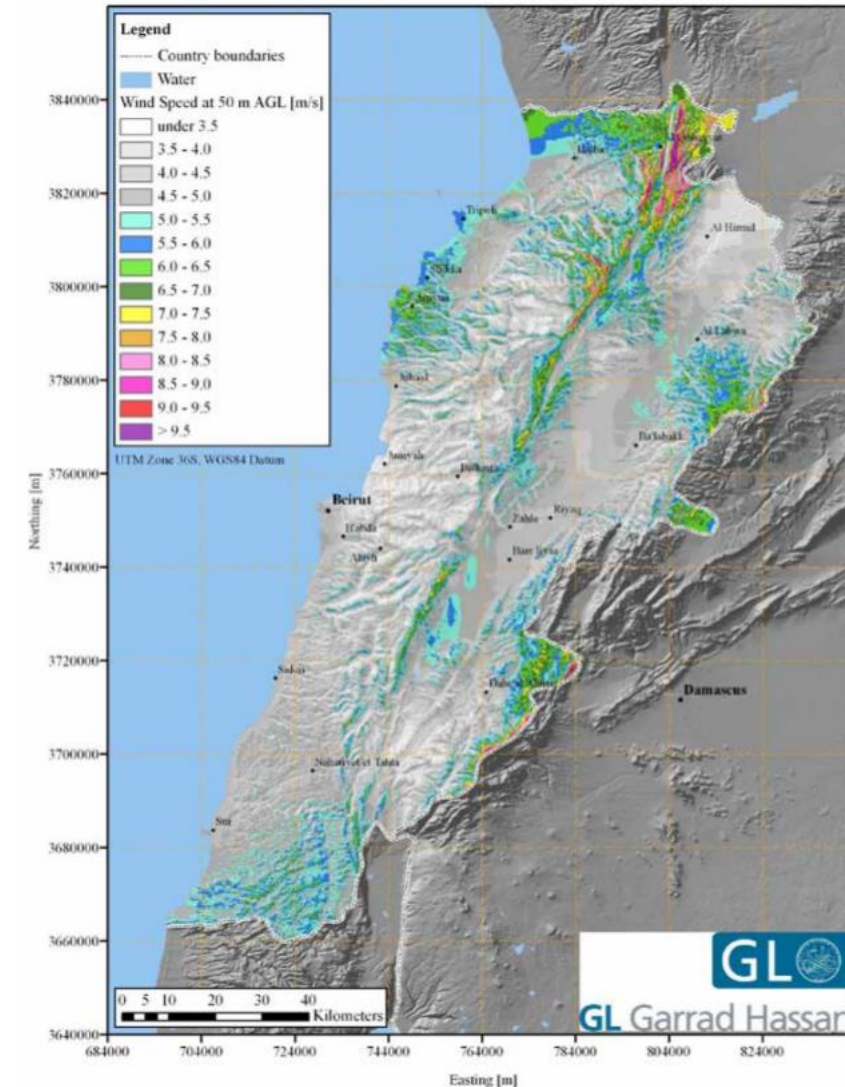

## 2.- Description of the Design Process

### a) Data collection: ii.- SWT wind resource assessment



## Sources of wind data: Wind Atlas and Reanalysis datasets

Resource	Source	Time Resolution	Spatial Resolution	Component	Heights (m)	Planning Level	Coverage
Wind	Global Wind Atlas	Year	250 m	WS, Weibull distribution	10, 50, 100, 200	LTES, Geo-spatial	World
	New European Wind Atlas (NEWA)	30 min	Meso 3 km Micro 250 m <sup>1</sup>	WS, WD, T, $\rho$ and 23 others	10, 50, 75 100, 150, 200, 250 and 500	Dispatch	Europe
	NASA-POWER	Month	30 km	WS and many others	50	LTES, Geo-spatial	World

Dataset Acronym	Dataset Whole Name	Time Period	Time Resolution	Horizontal Resolution	Variables
CFSR	Climate Forecast System Reanalysis	1979–now	most: 6 h; some: 1 h	38 km	WS: 10 m
MERRA-2	Modern-Era Retrospective Analysis for Research and Applications	1993–now	1 h	50 km	WS, WD: 50 m
ECMWF/ERA5	European Center for Medium-Range Weather Forecast/ECMWF Reanalysis v5	1979–now	1h	31 km	WS, WD: 10 and 100 m

Source: Arribas, L.; Lechón, Y.; Perula, A.; Domínguez, J.; Ferres, M.; Navarro, J.; Zarzalejo, L.F.; García Barquero, C.; Cruz, I. Review of Data and Data Sources for the Assessment of the Potential of Utility-Scale Hybrid Wind–Solar PV Power Plants Deployment, under a Microgrid Scope. *Energies* **2021**, *14*, 7434. <https://doi.org/10.3390/en14217434>

## 2.- Description of the Design Process

### a) Data collection: ii.- SWT wind resource assessment



GLOBAL WIND ATLAS  
GLOBAL SOLAR ATLAS | ENERGYDATA.INFO

Search...



About

Download

Contact

Help ?

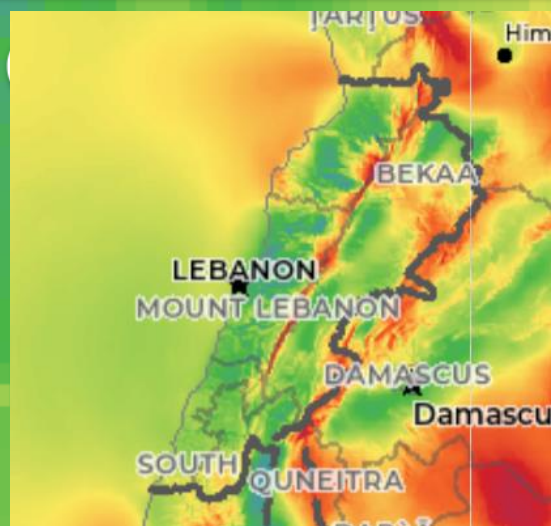

- Wind speed at several heights
- Wind direction
- Roughness
- Altitude

<https://globalwindatlas.info/>

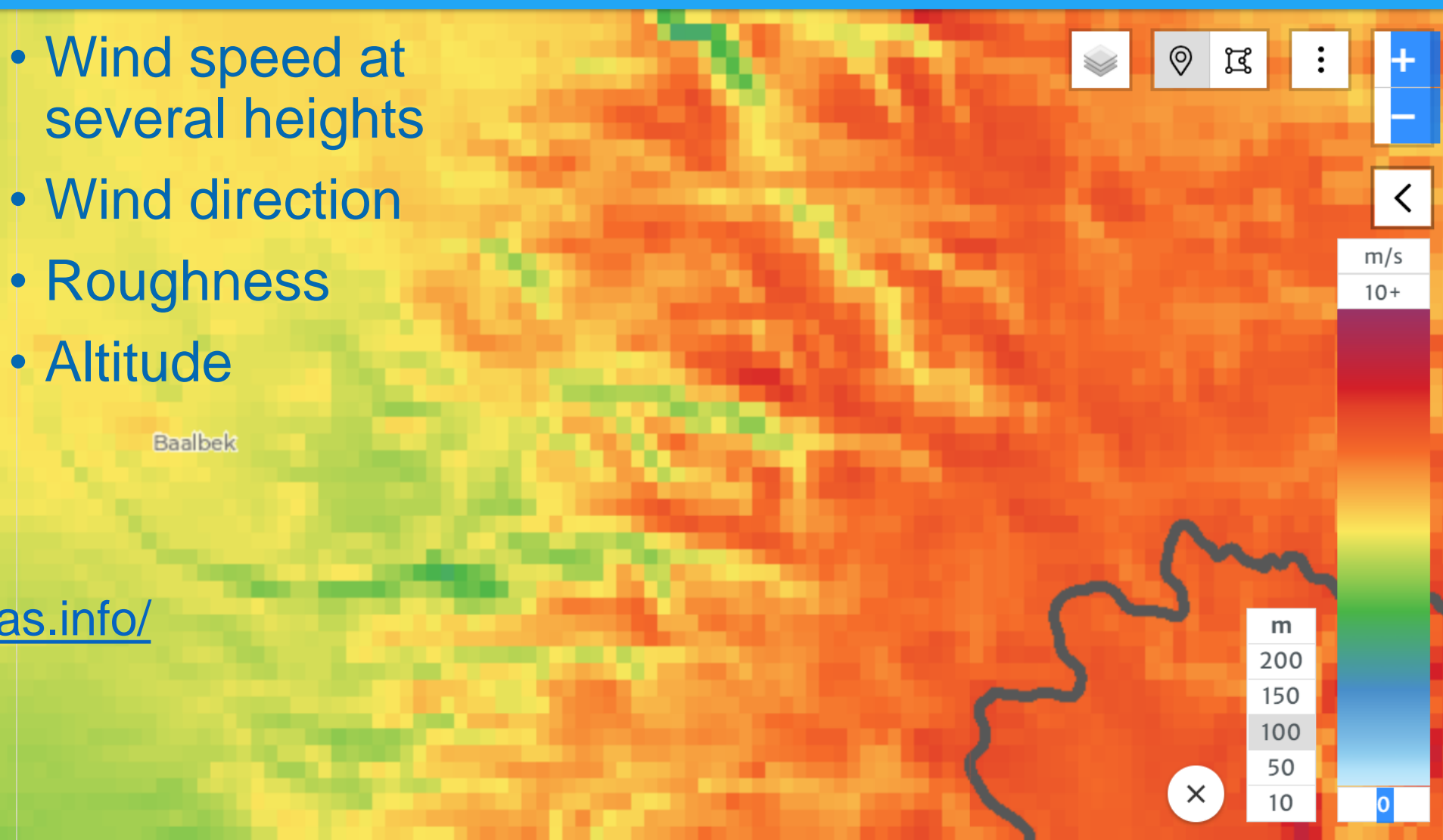

## 2.- Description of the Design Process

### a) Data collection: ii.- SWT wind resource assessment



ArcGIS World Geocoding Service

## NASA POWER Viewer

- Hourly data
- Wind speed at several heights
- Wind direction
- And more...
- Used by HOMER

<https://power.larc.nasa.gov/data-access-viewer/>

POWER Single Point

#### 1. Choose a User Community

Renewable Energy

#### 2. Choose a Temporal Average

Hourly

#### 3. Enter Lat/Lon or Add a Point to Map



33.9663

(-90 to +90 decimal degrees)

Clear

36.2589

(-180 to +180 decimal degrees)

## 2.- Description of the Design Process

### a) Data collection: ii.- SWT wind resource assessment



UN  
DP

FUNDED BY THE EUROPEAN UNION



Help ▾

Downloads

News

Sign up

Login ▾

Kyrenia

Point Country

Search by location

Lat  Lon

Solar PV

Wind

Dataset

▾

Select a year of data

Capacity (kW)

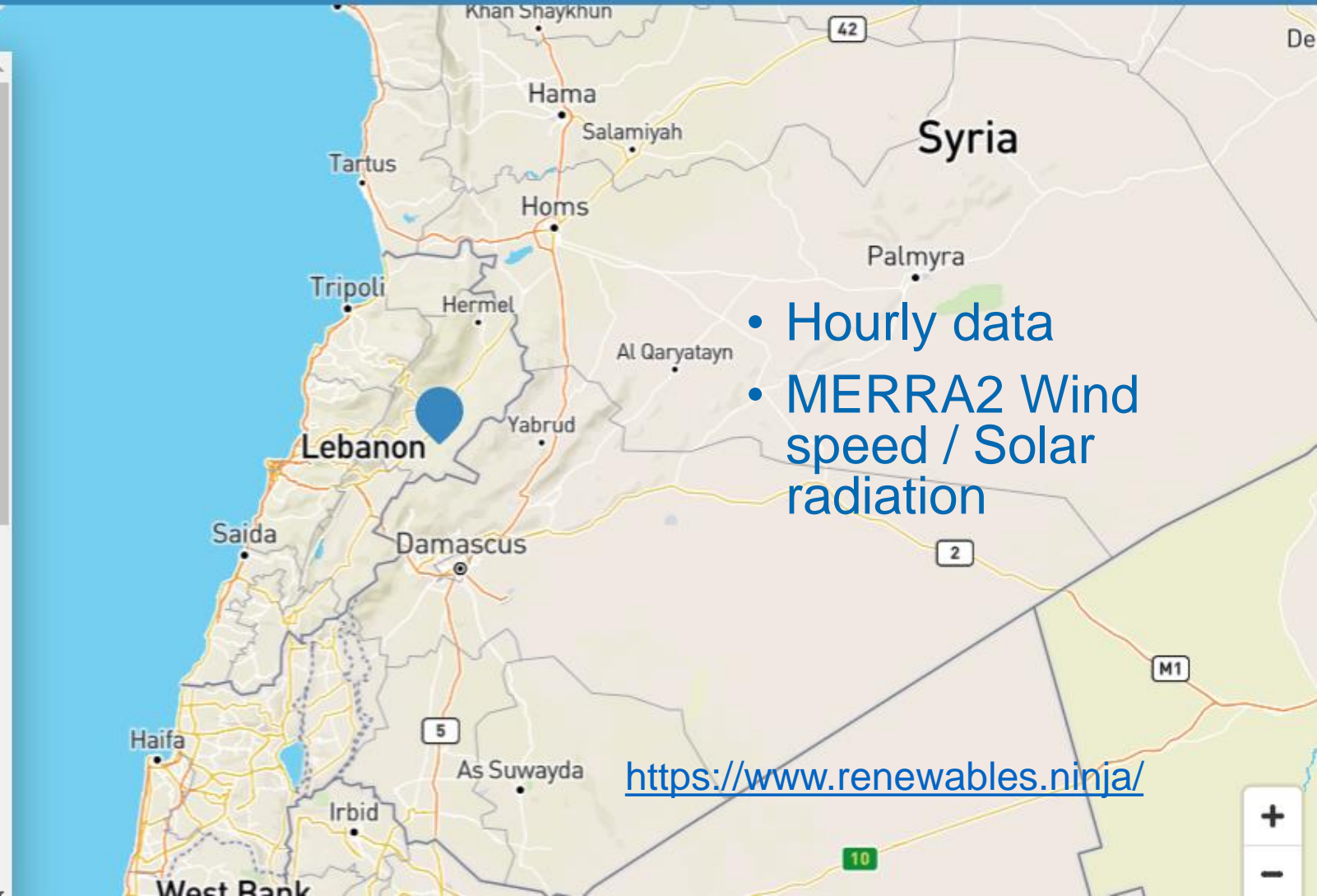

- Hourly data
- MERRA2 Wind speed / Solar radiation

<https://www.renewables.ninja/>

## 2.- Description of the Design Process

### a) Data collection: ii.- SWT wind resource assessment



Login/register

Home Search Datasets Applications Toolbox Support Live

## ERA5 hourly data on single levels from 1979 to present

- Hourly data
- Many meteorological parameters

WARNING 2021-06-25: Variable "Orography" is now named "Geopotential". No change in the data themselves. Previous API requests asking for "Orography" will fail now. To download the corresponding data the API request should ask for "Geopotential".

Overview

Download data

Quality assessment

Documentation

<https://cds.climate.copernicus.eu/cdsapp#!/dataset/reanalysis-era5-single-levels?tab=form>

### Contact

[ECMWF Support Portal](#)

### Licence

Licence to use Copernicus Products



## 2.- Description of the Design Process

### a) Data collection: ii.- SWT wind resource assessment



**MERRA-2 / ERA5 wind data can also be downloaded with other software, such as Windographer / Windnavigator**

Windographer Data Downloader

#### Download from Windnavigator

Location

Point of interest: N34.095° E36.310°

Please select a grid point on the map

Request Data Set

Selected Data Source: ERA5

- MERRA-1
- MERRA-2
- ERA5

Account Settings - \*\*\*\*\*

Username \*\*\*\*\*

Password ●●●●●●

[Click here to create a free Windnavigator account](#)

Network Settings

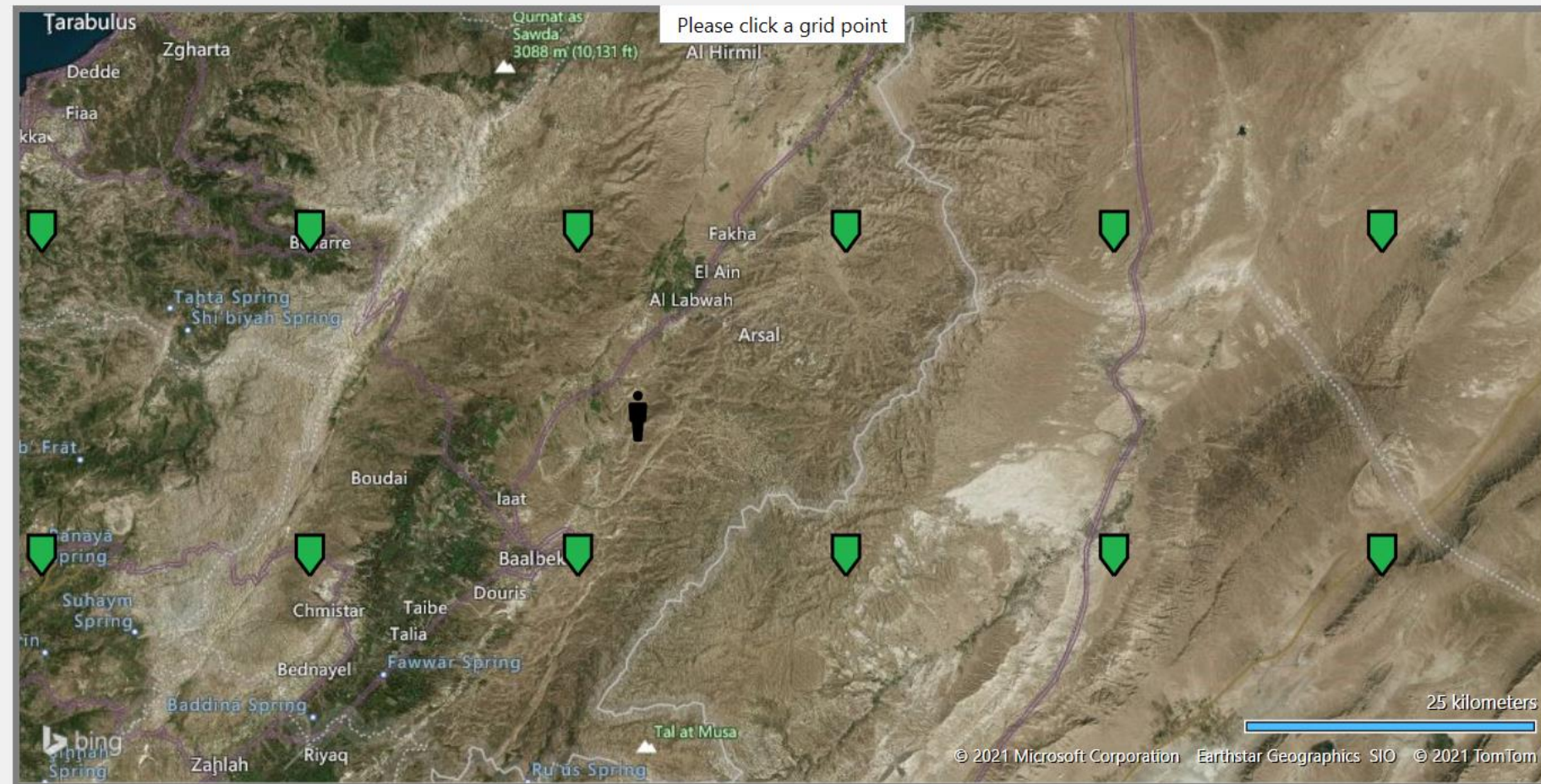



## 2.- Description of the Design Process

### a) Data collection: ii.- SWT wind resource assessment



FUNDED BY THE EUROPEAN UNION

## Data analysis

- Data both from campaign and/or datasets
- Data quality check
- Data processing if necessary
- If measured data are available: MCP
  - Measure for some representative months
  - Correlate with some of the available sources – spatial extrapolation
  - Predict performance – Temporal extrapolation
- *Windographer* software (SW) is a helpful tool for wind data analysis

Date	Time	Temp Out	Hi Temp	Low Temp	Out Hum	Dew Pt.	Wind Speed
07/29/20	10:45 a	29.6	29.6	29.2	30	10.2	
07/29/20	11:00 a	30.5	30.5	29.6	27	9.4	
07/29/20	11:15 a	30.4	30.6	30.2	26	8.7	
07/29/20	11:30 a	30.5	30.5	29.7	27	9.4	
07/29/20	11:45 a	30.4	30.6	30.1	26	8.7	
07/29/20	12:00 p	30.8	31.2	30.3	30	11.2	
07/29/20	12:15 p	29.7	30.8	29.7	31	10.7	
07/29/20	12:30 p	29.2	29.7	29.1	31	10.3	
07/29/20	12:45 p	30.1	30.1	29.2	30	10.6	
07/29/20	1:00 p	29.9	30.2	29.7	29	10.0	
07/29/20	1:15 p	29.6	30.1	29.4	30	10.1	
07/29/20	1:30 p	30.2	30.2	29.6	29	10.2	
07/29/20	1:45 p	30.4	30.4	30.2	28	9.8	
07/29/20	2:00 p	30.6	30.6	30.3	28	10.0	
07/29/20	2:15 p	30.5	30.7	30.1	28	9.9	
07/29/20	2:30 p	30.1	30.5	30.1	29	10.1	
07/29/20	2:45 p	29.8	30.1	29.7	30	10.3	
07/29/20	3:00 p	29.8	29.8	29.7	30	10.3	
07/29/20	3:15 p	29.6	29.8	29.5	31	10.6	
07/29/20	3:30 p	29.9	29.9	29.6	30	10.4	
07/29/20	3:45 p	30.3	30.3	29.8	29	10.3	
07/29/20	4:00 p	30.5	30.6	30.2	30	11.0	
07/29/20	4:15 p	30.2	30.4	30.2	31	11.2	
07/29/20	4:30 p	29.7	30.2	29.6	32	11.3	
07/29/20	4:45 p	29.7	29.8	29.7	31	10.8	
07/29/20	5:00 p	29.6	29.8	29.5	32	11.1	
07/29/20	5:15 p	29.3	29.6	29.2	33	11.3	
07/29/20	5:30 p	29.2	29.3	29.1	32	10.8	
07/29/20	5:45 p	28.7	29.2	28.7	34	11.3	

# 2.- Description of the Design Process

## a) Data collection: ii.- SWT wind resource assessment



### Data analysis: quality check

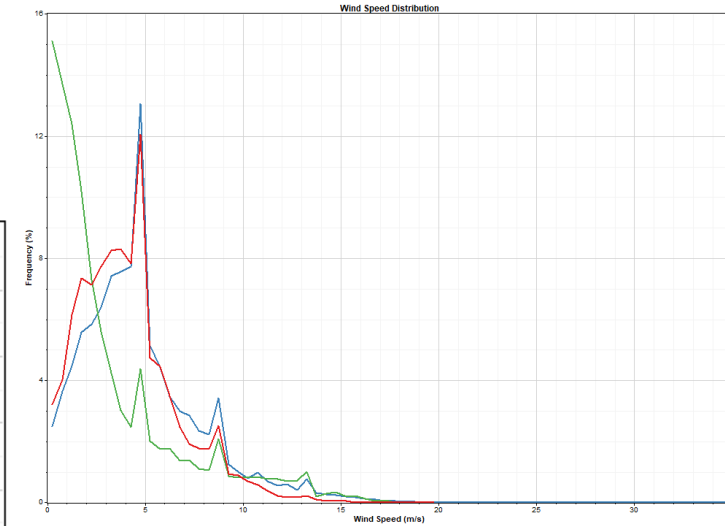
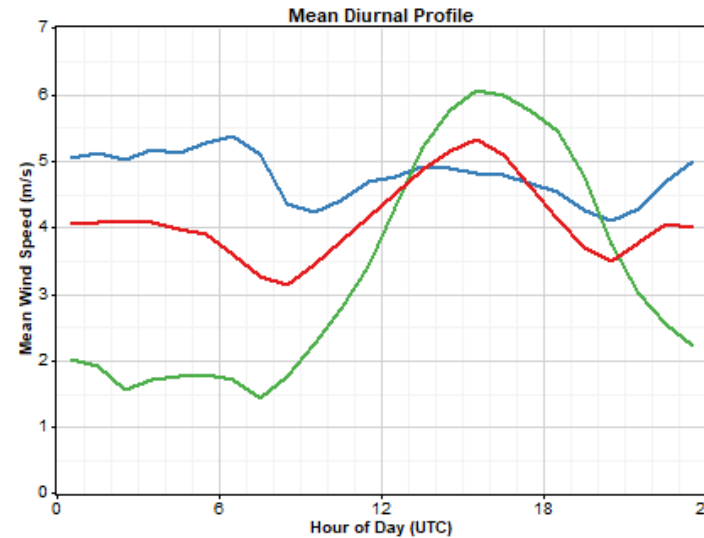
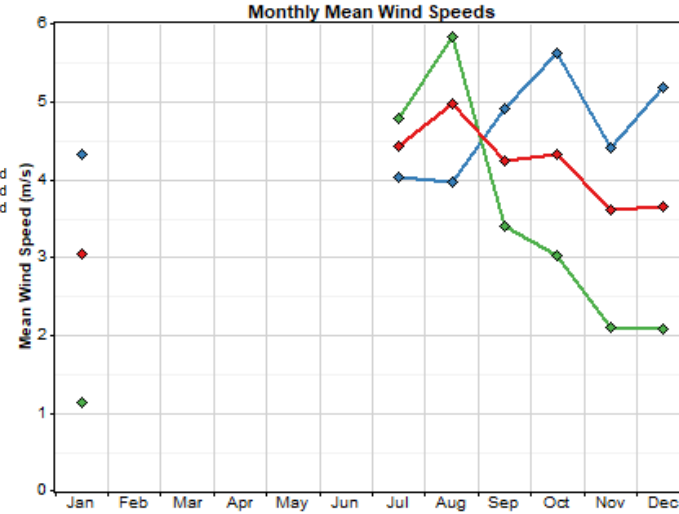

# Data analysis: MCP



Onsite Data | Long Term Data | LT Adjustments

Adjustments

M1^R

Add Remove ↑ ↓

Adjustment properties

Onsite M1  
Reference R

Time step of comparison  
60 minutes

Limit concurrent period to  
29/07/2020 to 31/10/2020

Description

Onsite vs. Reference | Correlate Speed | Correlate Direction | Correlate Temperature | Synthesize Data

Synthesize speeds using Linear Least Squares (LLS)

Direction sectors: 1  
Yearly divisions: 1  
Force zero intercept: Yes

Create extended data set starting 01/01/1979 00:00  
ending 11/01/2021 12:00

Overwrite measured onsite data with synthetic data

Extend Onsite Data Set

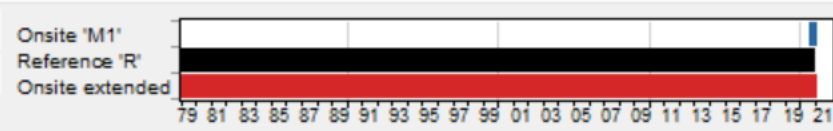

Display summary

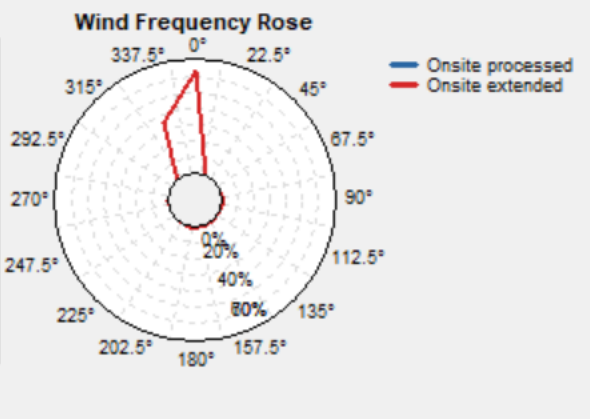
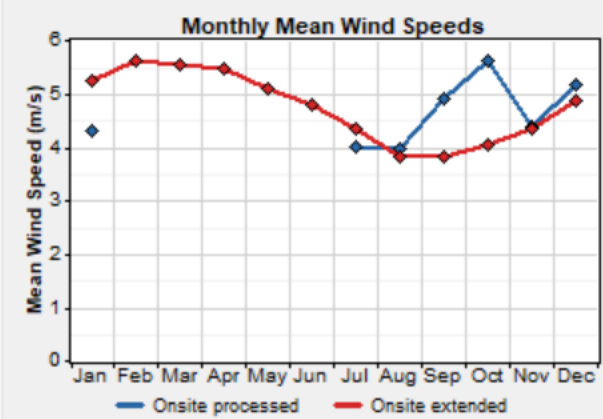
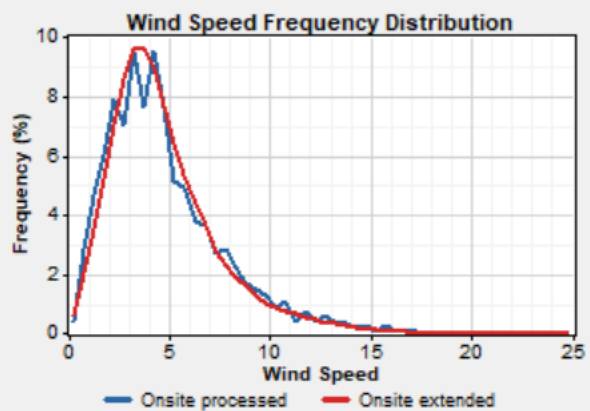
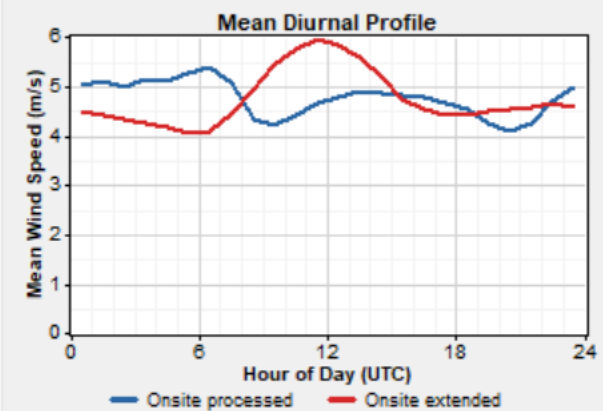

		Onsite Data Set 'M1'		
		Original	Processed	Extended
Period of record	Start	29/07/2020 10:45	29/07/2020 10:00	01/01/1979 00:00
	End	11/01/2021 11:45	11/01/2021 12:00	11/01/2021 12:00
	Duration	5.5 months	5.5 months	42 years
Time step		15 minutes	60 minutes	60 minutes
	Time steps	15,732	3,935	368,427
Speed @ 0 m	Mean	4.786 m/s	4.786 m/s	4.773 m/s
	MoMM	4.786 m/s	4.786 m/s	4.773 m/s
		Change from original:		-0.27%
Dir. @ 41 m	Min.	0.000 m/s	0.200 m/s	0.000 m/s
	Max.	32.600 m/s	19.800 m/s	24.683 m/s
	Weibull k	1.568	1.625	1.688
	Weibull A	5.328 m/s	5.346 m/s	5.347 m/s
	WPD	172 W/m2	164 W/m2	155 W/m2
	LCA factor	0.997		
Temp. @ 0 m	Time steps	2,350	588	588
	Mean	347.8°	347.8°	347.8°
	Time steps	15,732	3,935	368,427
Temp. @ 0 m	Mean	13.56 °C	13.56 °C	13.78 °C
	MoMM	13.56 °C	13.56 °C	13.78 °C
	LCA factor	1.00079		

Text Report... PDF Report... Scale Onsite Data Set... Export Extended Data Set...

## 2.- Description of the Design Process

### a) Data collection: ii.- **SWT wind resource assessment**



## Analysis of the influence of obstacles: selection of the site

- Rule of thumb
- *myWindTurbine SW* may help

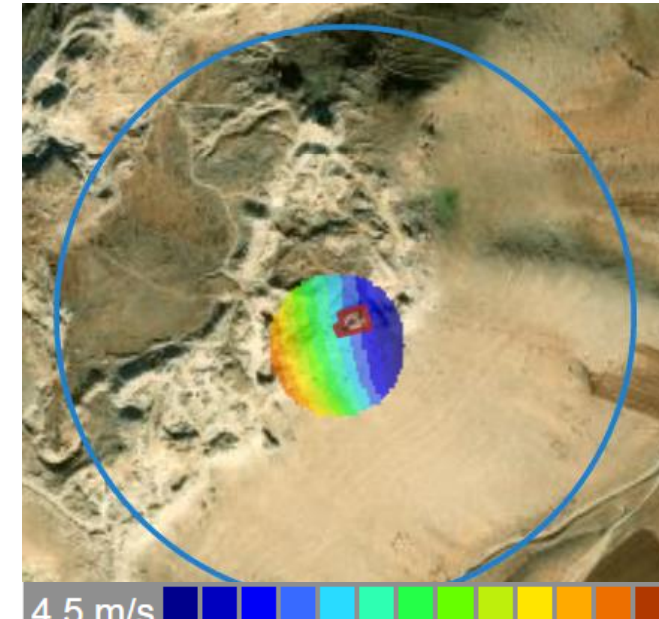
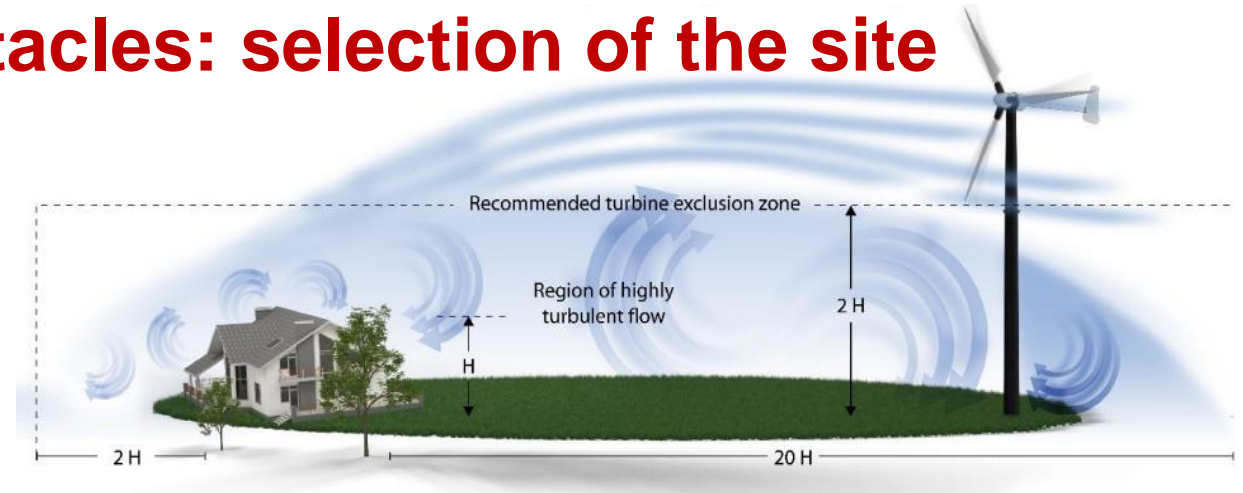

## 2.- Description of the Design Process

### a) Data collection: **iii.- SWT existing technology**

- Quality is an issue:
  - IEC standards
  - Independent tests
  - Documented experiences
- Market is highly changing
- An starting point: the Folkecenter Small Wind Catalogue

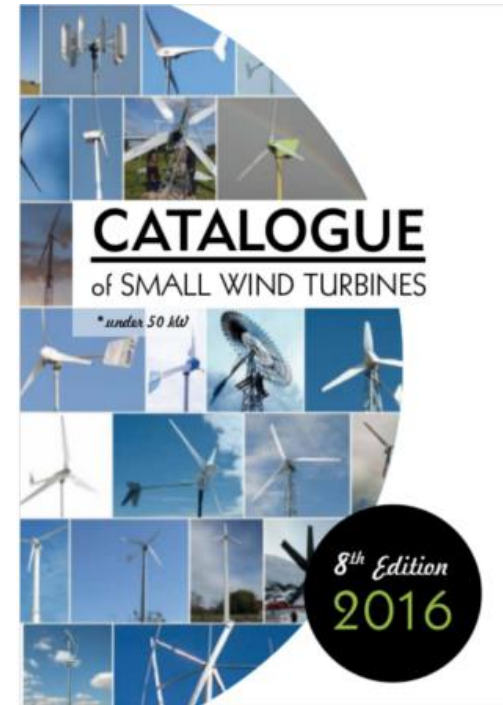

## 2.- Description of the Design Process

### b) Sizing study



- i. Design tools
  - Levels of analysis
  - Brief description of HOMER Software
- ii. Feasibility study with HOMER Pro
  - Project inputs
  - Analysis
  - Results
  - Criteria to choose the optimum

## 2.- Description of the Design Process

### b) Sizing study: i.- Design tools: levels of analysis

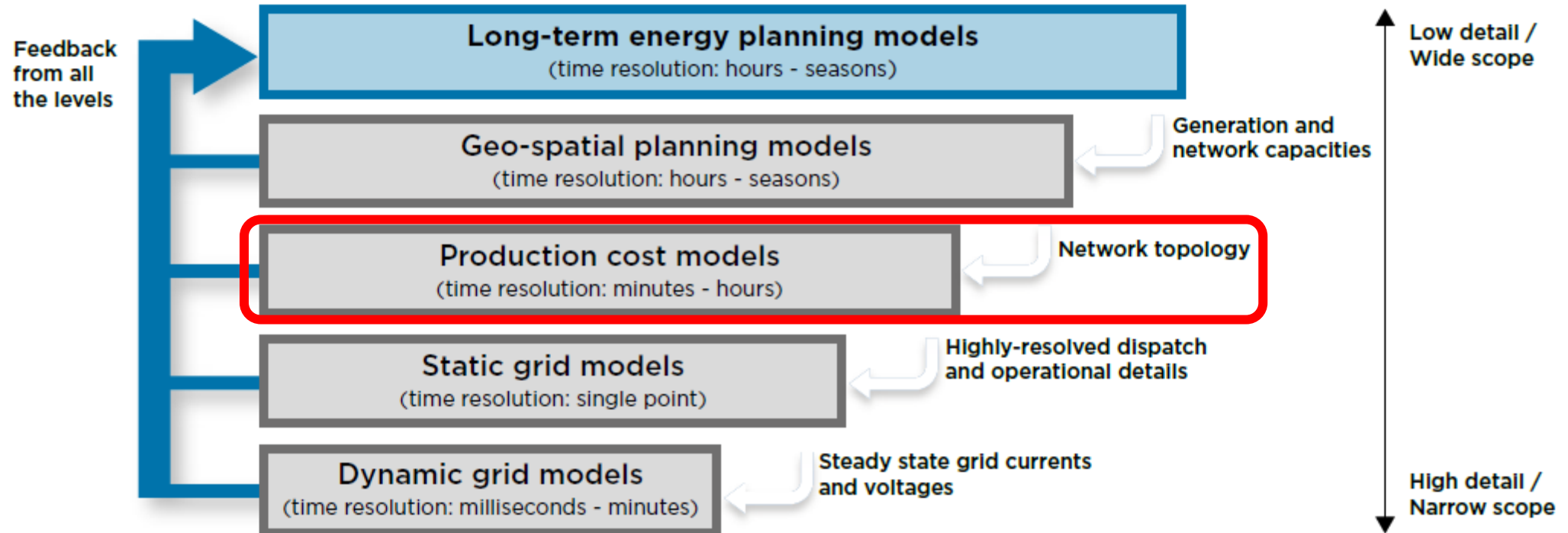

IRENA (2017), Planning for the Renewable Future: Long-term modelling and tools to expand variable renewable power in emerging economies, International Renewable Energy Agency, Abu Dhabi. [https://www.irena.org/-/media/Files/IRENA/Agency/Publication/2017/IRENA\\_Planning\\_for\\_the\\_Renewable\\_Future\\_2017.pdf](https://www.irena.org/-/media/Files/IRENA/Agency/Publication/2017/IRENA_Planning_for_the_Renewable_Future_2017.pdf)

## 2.- Description of the Design Process

### b) Sizing study: i.- Design tools: levels of analysis



### Example: ABB's Coral Bay Wind-Diesel system design

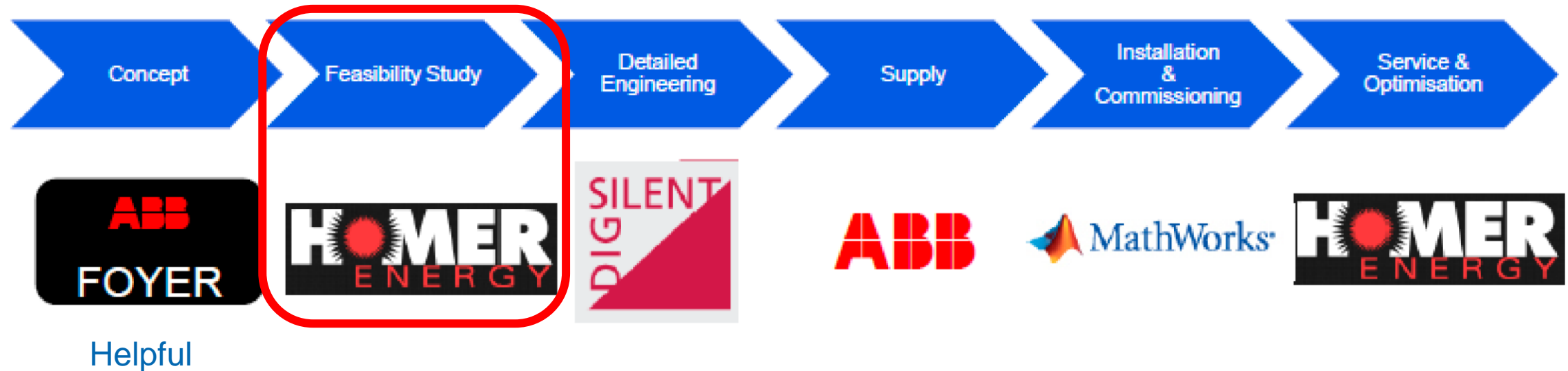

Source: Zimmermann, J. Case study for CORAL BAY Energy modelling for a WIND DIESEL and stabilization hybrid system. In Proceedings of the Microgrid Deployment Workshop Fall, Barcelona, Spain, 20 September 2014.

# Brief introduction to HOMER SW



- NREL: 1992-2008 - HOMER Legacy
- Since 2009, HOMER Energy – HOMER Pro
- Since 2019, acquired by UL: HOMER Energy by UL
- >250,000 users in 193 countries

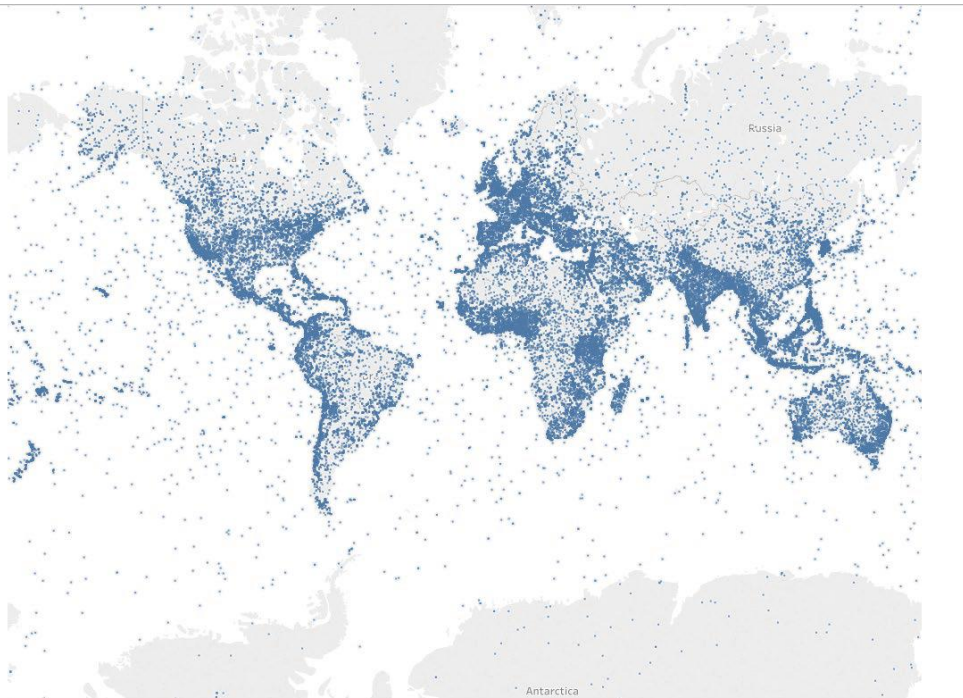

- > 3 millions HOMER files
- > 70,000 projects since 2014

# Which is the best option?

Solar  
Wind  
Hydro  
Geothermal  
Biomass  
New Storage Techs.  
Electric Vehicles



Fuel Cells  
Micro-turbines  
Micro-grids  
Demand Response  
Load Management  
Smart grids

- Too many options!
- Depends on
  - Resources
  - Loads
  - Equipment prices
  - Equipment performance
- HOMER fits the pieces together, including “time”

# Who uses HOMER?



## Developers



## Component Suppliers



## Education



## Engineering Firms



## Government & Financial Institutions



## Utilities



# HOMER as a communication tool

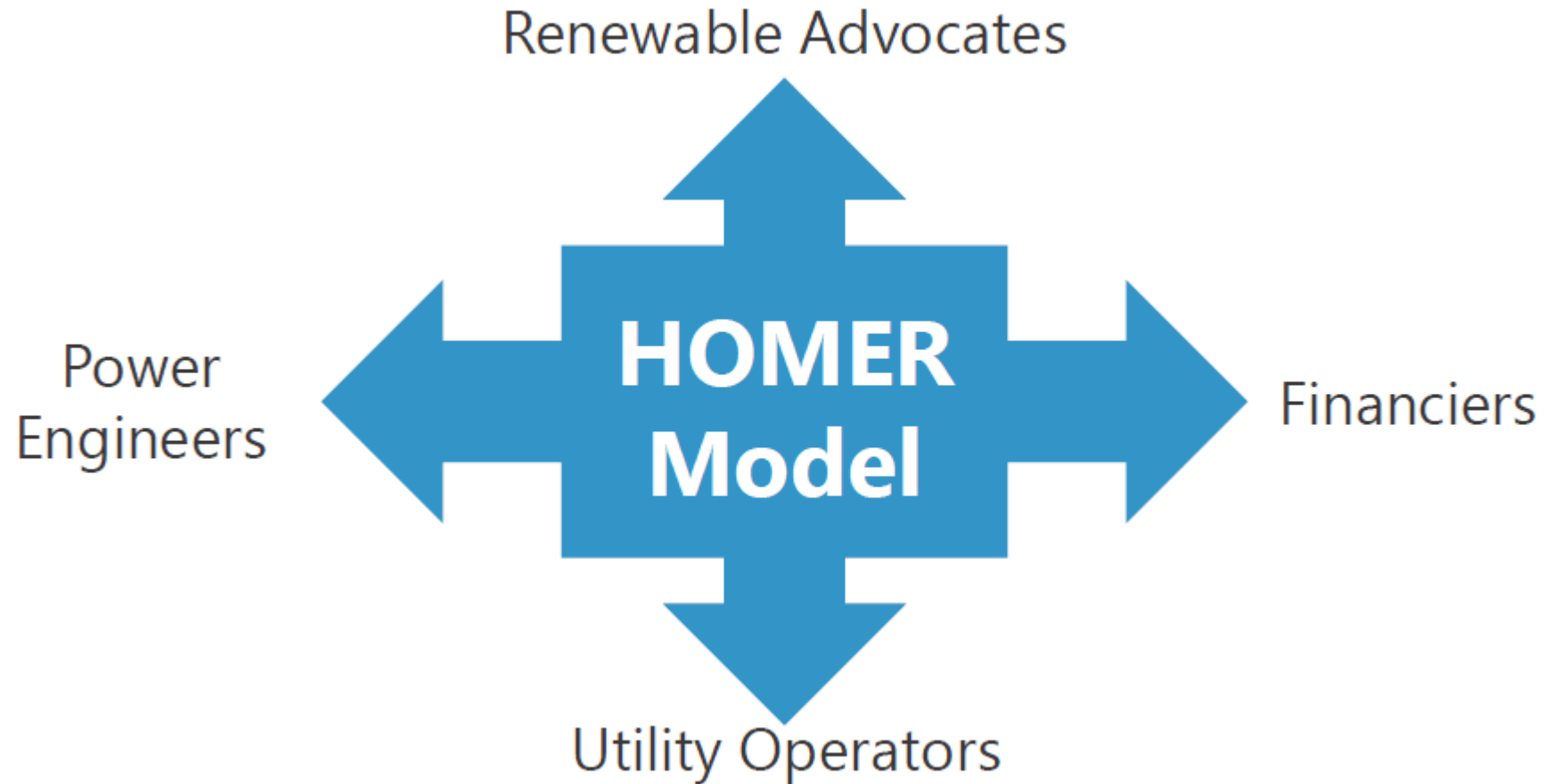

## 2.- Description of the Design Process

### b) Sizing study: ii.- Feasibility study with HOMER Pro



#### Project Inputs



Economics

Load Profile

Site-Specific  
Renewable Resources

System Components

#### Analysis

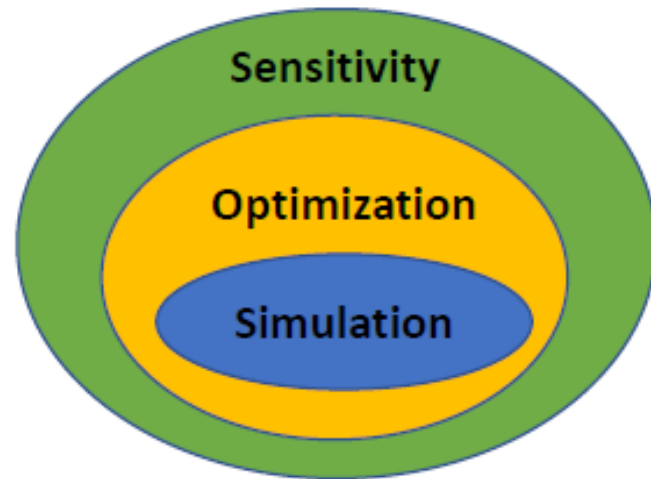

#### Results



Economics & Engineering

System Sizing

Performance Details

Financials

Various Reports

## 2.- Description of the Design Process

### b) Sizing study: ii.- Feasibility study with HOMER Pro



## Project inputs (I)

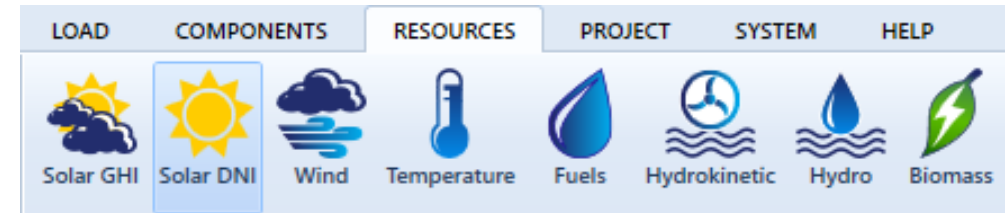
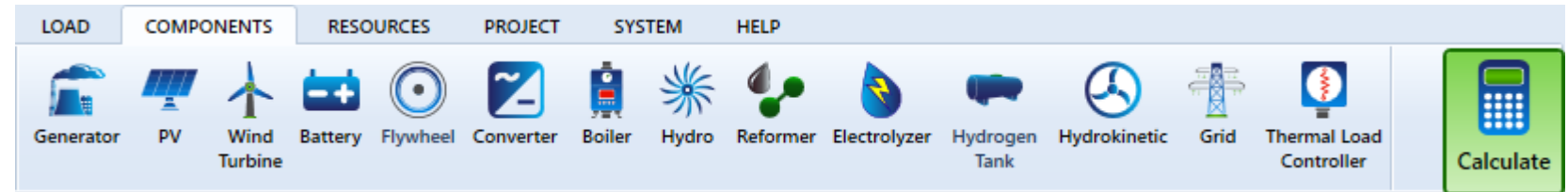
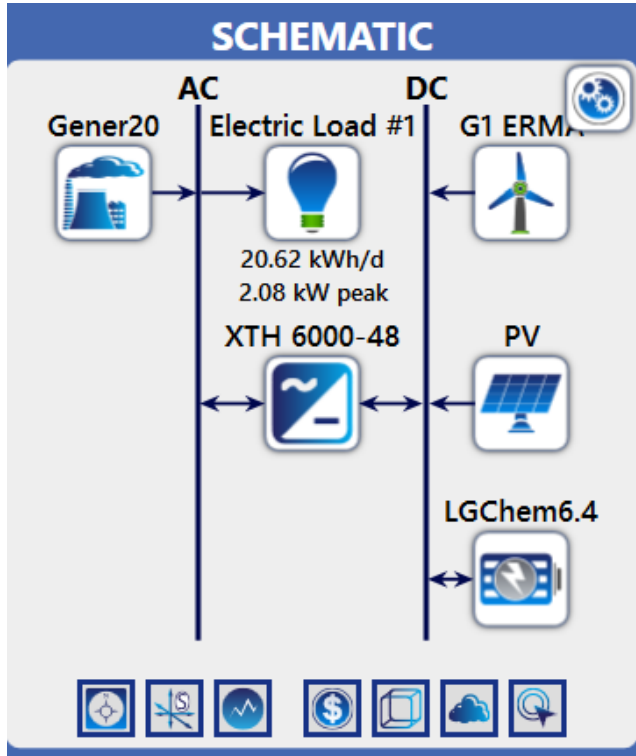

## 2.- Description of the Design Process

### b) Sizing study: ii.- Feasibility study with HOMER Pro



#### ➤ Economics

- Discount rate
- Inflation rate
- Tax and incentives
- Project lifetime
- Fuel (type and cost)
- Electricity tariff

#### ➤ Load profile

- 8760 hourly data / 1 year
- May be synthetically generated

## Project inputs (II)

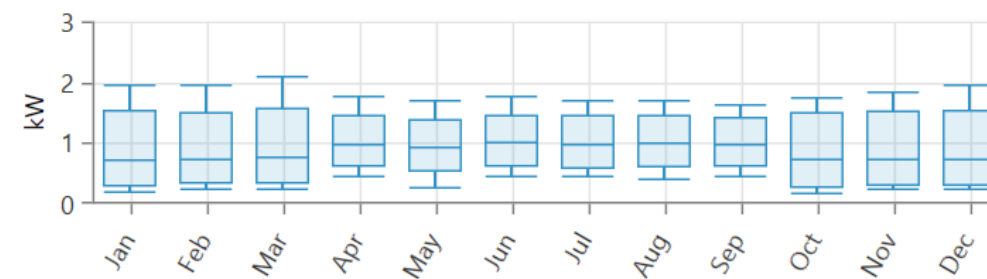
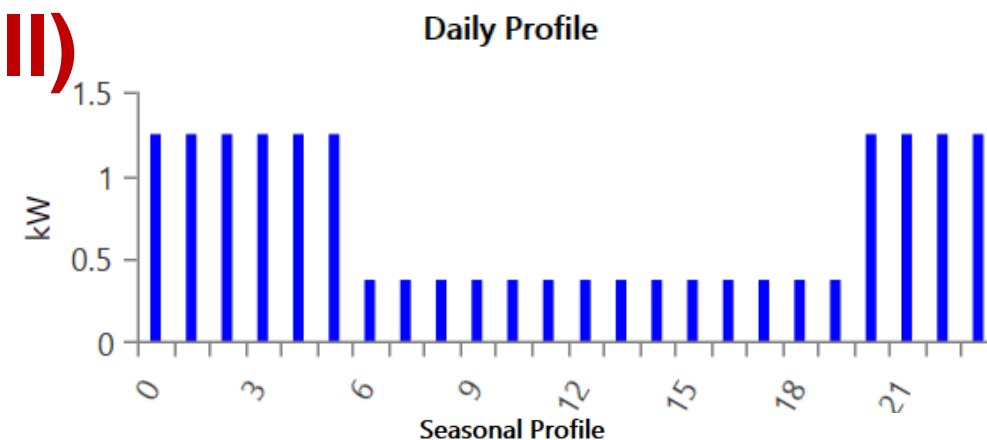

Yearly Profile

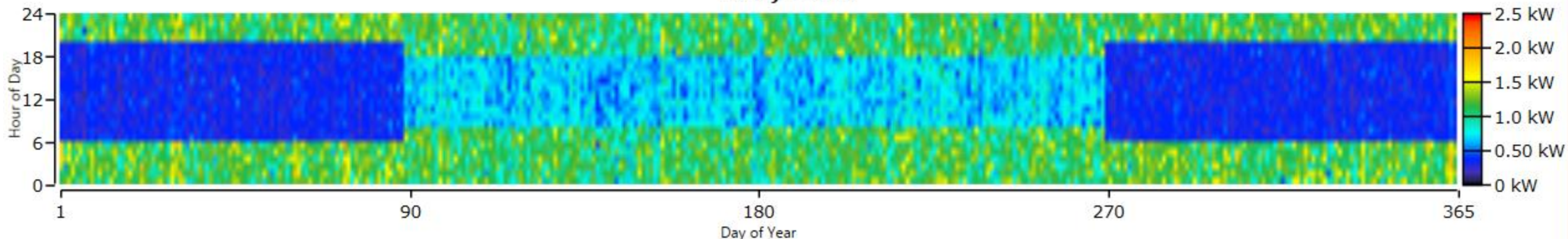

## 2.- Description of the Design Process

### b) Sizing study: ii.- Feasibility study with HOMER Pro



## Project inputs (III): Site-specific RE resources

### ➤ Wind resource

- Wind speed, 8760 values, m/s
- Altitude above sea level (m)
- Anemometer height (m)
- Wind speed profile (Logarithmic or Power law)

### ➤ Solar Global Horizontal Irradiance

### ➤ Temperature (optional)

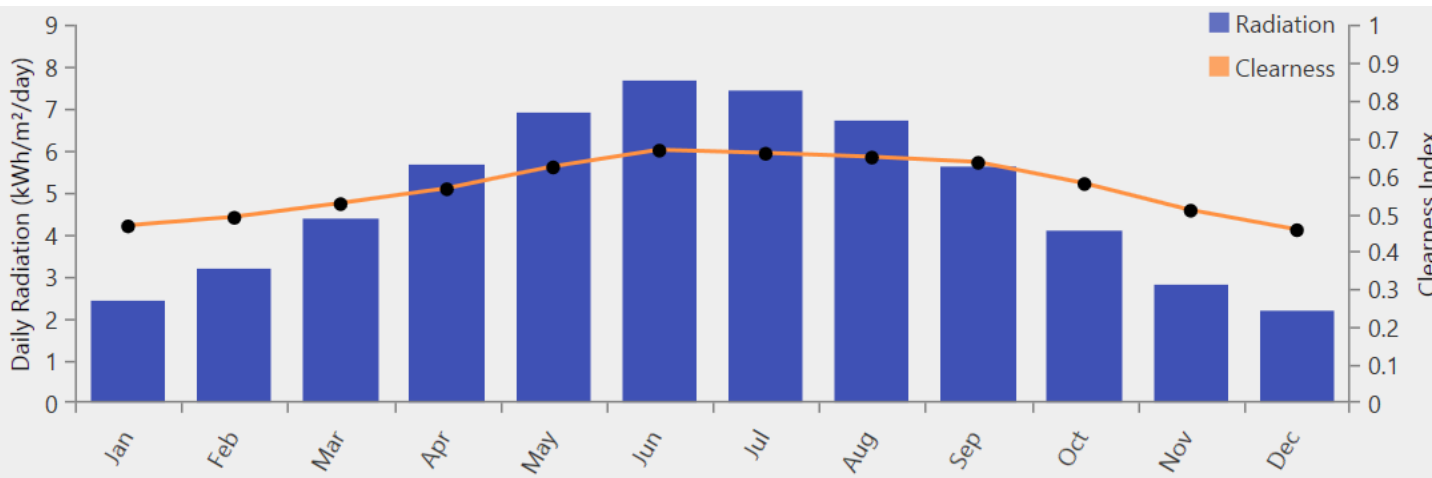
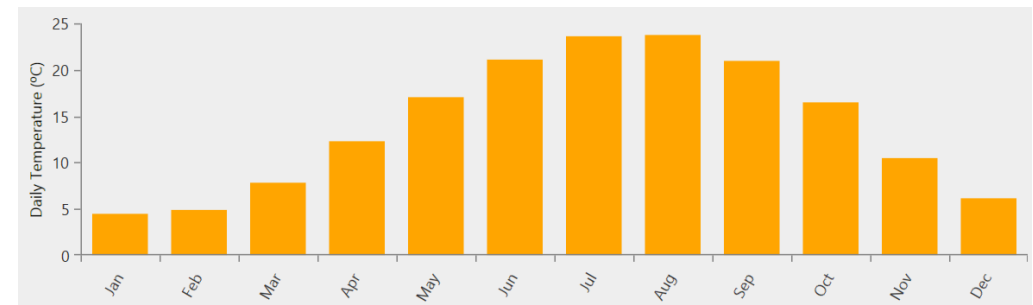
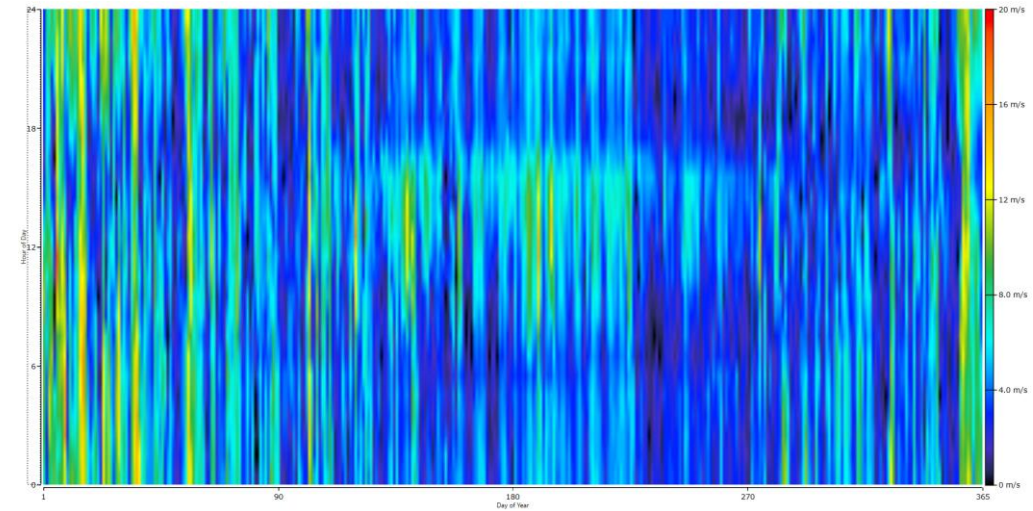

## 2.- Description of the Design Process

### b) Sizing study: ii.- Feasibility study with HOMER Pro



## Project inputs (IV): System components – the Wind Turbine

### ➤ Performance

- Power curve
- Lifetime
- Hub height
- AC or DC coupled
- Losses

### ➤ Costs (Capital, Replacement, O&M)

### ➤ Quantity optimization

- Optimizer
- Search space

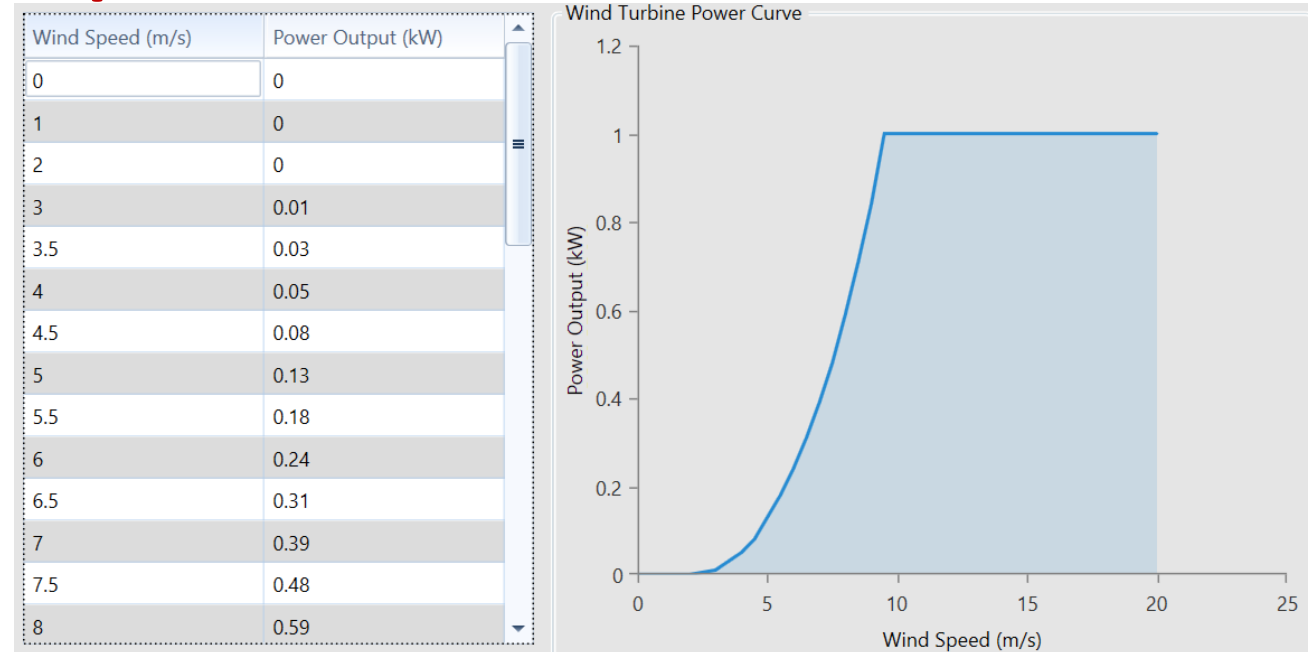

The figure displays a table of costs for wind turbine components. The table has four columns: Quantity, Capital (\$), Replacement (\$), and O&M (\$/year). The table shows the costs for 1 and 8 units of the component. The multiplier for each column is 4.

Quantity	Capital (\$)	Replacement (\$)	O&M (\$/year)
1	\$9,000.00	\$7,200.00	\$270.00
8	\$28,000.00	\$22,400.00	\$840.00

Multiplier: 4 4 {..}

## 2.- Description of the Design Process

### b) Sizing study: ii.- Feasibility study with HOMER Pro



#### ➤ Hourly energy balance

- The HOMER processor does this invisibly.
- It compares energy supply and demand for each hour.
- It decides how to operate the supply sources (generators, batteries, grid).

#### ➤ Simulation - Time varying loads & resources require chronological analysis for entire year

- Estimates the costs and determine the feasibility of designing a system in 8760 hours in a year.

#### ➤ Optimization - LCOE, reliability, max. renewables, & resiliency

- Simulates the configuration of each system
- Displays a list of systems sorted by Net Present Cost (NPC)

#### ➤ Sensitivity Analysis - Evaluates uncertain inputs: prices, weather, loads, ....

## HOMER Analysis layers

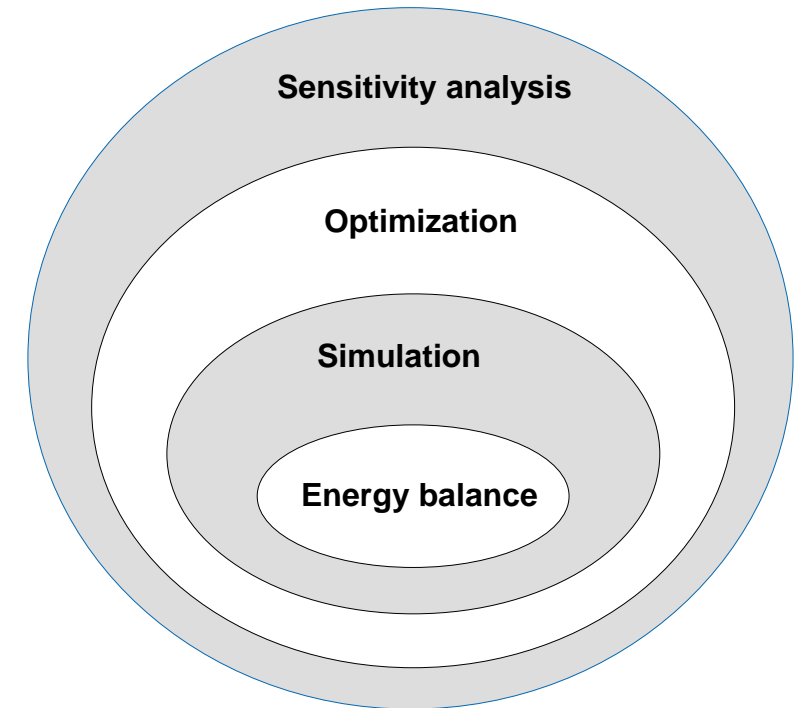

## 2.- Description of the Design Process

### b) Sizing study: ii.- Feasibility study with HOMER Pro



# Techno-economic Analysis

## ➤ Performance model

- Energy production
- Emissions reduction
- RE penetration

## ➤ Economic model

- Levelized Cost of Energy (LCOE)
- Net Present Cost (NPC)
- Cost breakdown
- Payback period

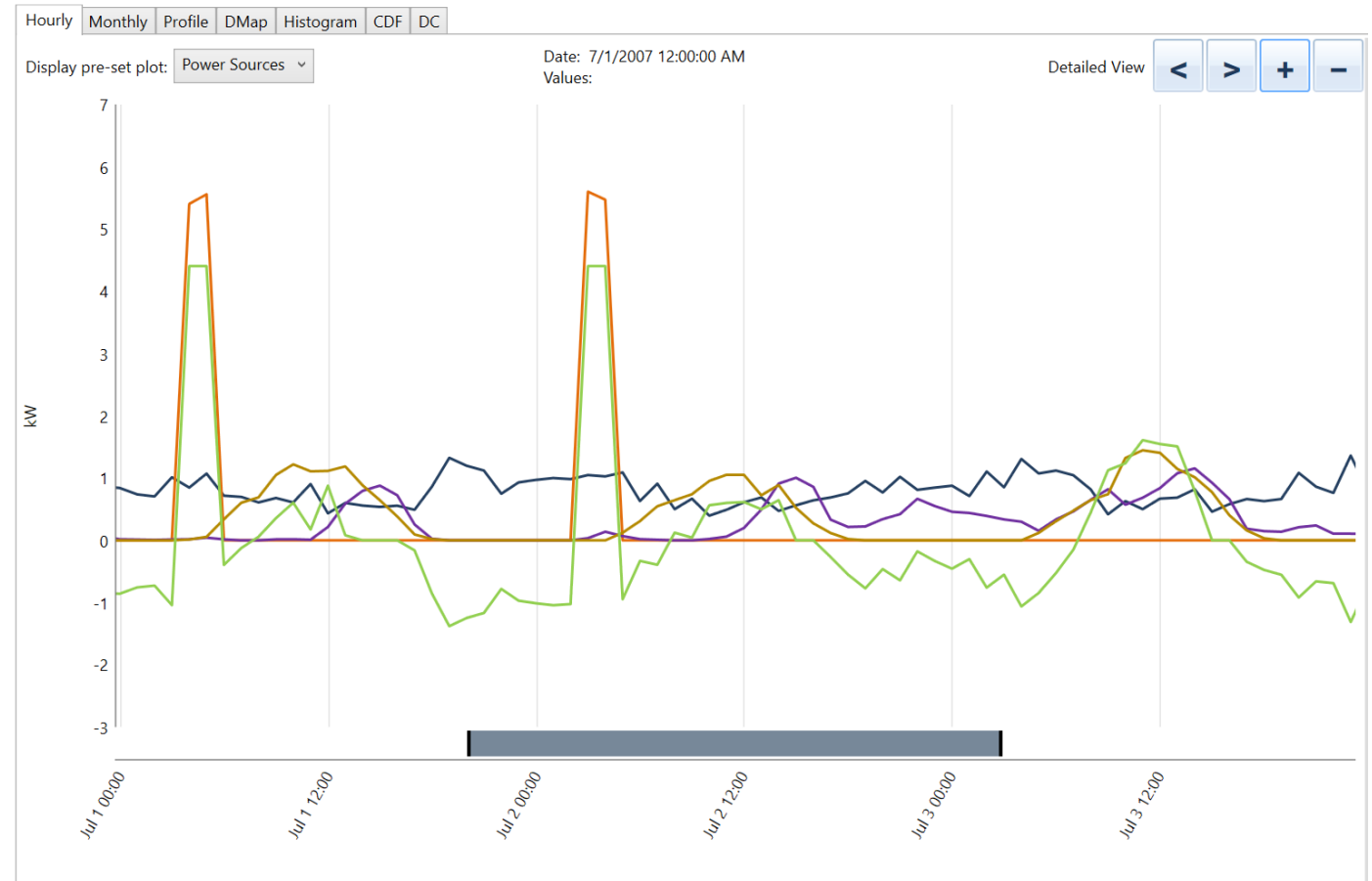

## 2.- Description of the Design Process

### b) Sizing study: ii.- Feasibility study with HOMER Pro



## Results (I): System sizing

Architecture					Cost				System			Gener20						
⚠	☀️	✈️	🏠	🔋	PV (kW)	G1 ERMA	Gener20 (kW)	LGChem6.4	XTH 6000-48 (kW)	NPC (\$)	COE (\$)	Operating cost (\$/yr)	Initial capital (\$)	Ren Frac (%)	Total Fuel (L/yr)	Hours	Production (kWh)	Fuel (L)
	☀️	✈️	🏠	🔋	2.00	3	20.0	2	4.50	\$51,604	\$0.530	\$2,185	\$23,357	67.5	733	475	2,447	733
	☀️		🏠	🔋	6.00		20.0	4	4.50	\$51,679	\$0.531	\$1,545	\$31,700	81.4	425	300	1,399	425
	✈️	🏠	🔋			6	20.0	2	4.50	\$56,130	\$0.577	\$2,544	\$23,243	65.0	788	505	2,636	788

Optimal System Type

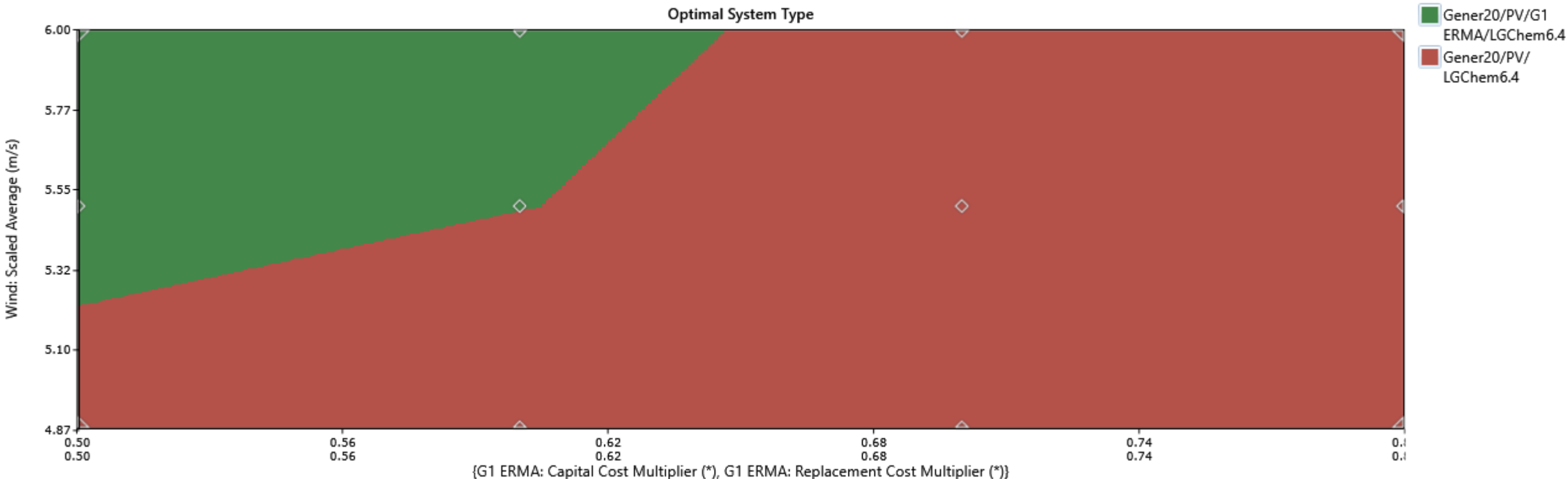

## 2.- Description of the Design Process

### b) Sizing study: ii.- Feasibility study with HOMER Pro



# Results (II): Performance details - System

Emissions

Cost Summary Cash Flow Compare Economics **Electrical** Fuel Summary Generac 20kW Protector Renewable Penetration LGChem RESU [6.4kWh] Generic flat plate PV Generic 1 kW ERMA Studer Xtender XTH 6000-48

Production	kWh/yr	%
Generic flat plate PV	2,959	25.6
Generac 20kW Protector	2,447	21.1
Generic 1 kW ERMA	6,166	53.3
<b>Total</b>	<b>11,571</b>	<b>100</b>

Consumption	kWh/yr	%
AC Primary Load	7,526	100
DC Primary Load	0	0
Deferrable Load	0	0
<b>Total</b>	<b>7,526</b>	<b>100</b>

Quantity	kWh/yr	%
Excess Electricity	3,522	30.4
Unmet Electric Load	0	0
Capacity Shortage	0	0

Quantity	Value	Units
Renewable Fraction	67.5	%
Max. Renew. Penetration	2,214	%

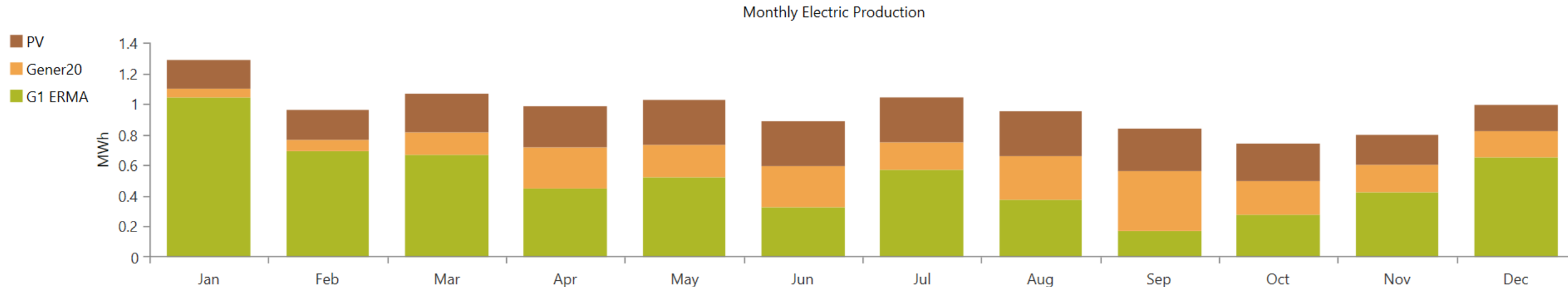

## 2.- Description of the Design Process

### b) Sizing study: ii.- Feasibility study with HOMER Pro



## Results (III): Performance details – Components (SWT)

Quantity	Value	Units
Total Rated Capacity	3.00	kW
Mean Output	0.704	kW
Capacity Factor	23.5	%
Total Production	6,166	kWh/yr

Quantity	Value	Units
Minimum Output	0	kW
Maximum Output	2.34	kW
Wind Penetration	81.9	%
Hours of Operation	8,095	hrs/yr
Levelized Cost	0.191	\$/kWh

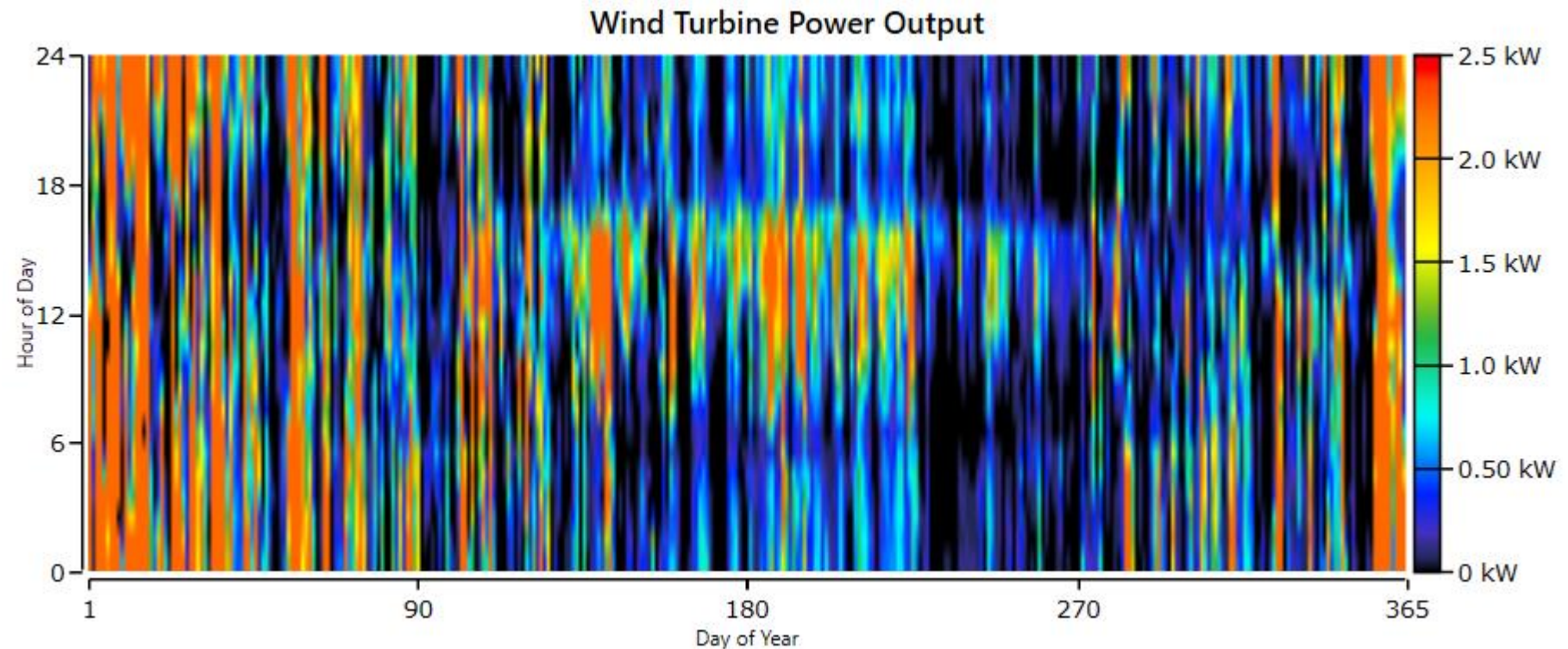

## 2.- Description of the Design Process

### b) Sizing study: ii.- Feasibility study with HOMER Pro



FUNDED BY THE EUROPEAN UNION

## Results (IV): Financials

Component	Capital (\$)	Replacement (\$)	O&M (\$)	Fuel (\$)	Salvage (\$)	Total (\$)
Generac 20kW Protector	\$0.00	\$0.00	\$7,187.70	\$8,944.48	-\$140.54	\$15,991.64
Generic 1 kW ERMA	\$8,657.14	\$2,207.97	\$5,595.77	\$0.00	-\$1,244.33	\$15,216.55
Generic flat plate PV	\$5,000.00	\$0.00	\$258.55	\$0.00	\$0.00	\$5,258.55
LGChem RESU [6.4kWh]	\$7,000.00	\$5,300.63	\$0.00	\$0.00	-\$718.67	\$11,581.95
Studer Xtender XTH 6000-48	\$1,800.00	\$763.69	\$465.39	\$0.00	-\$143.73	\$2,885.35
System	\$22,457.14	\$8,272.29	\$13,507.41	\$8,944.48	-\$2,247.28	\$50,934.04

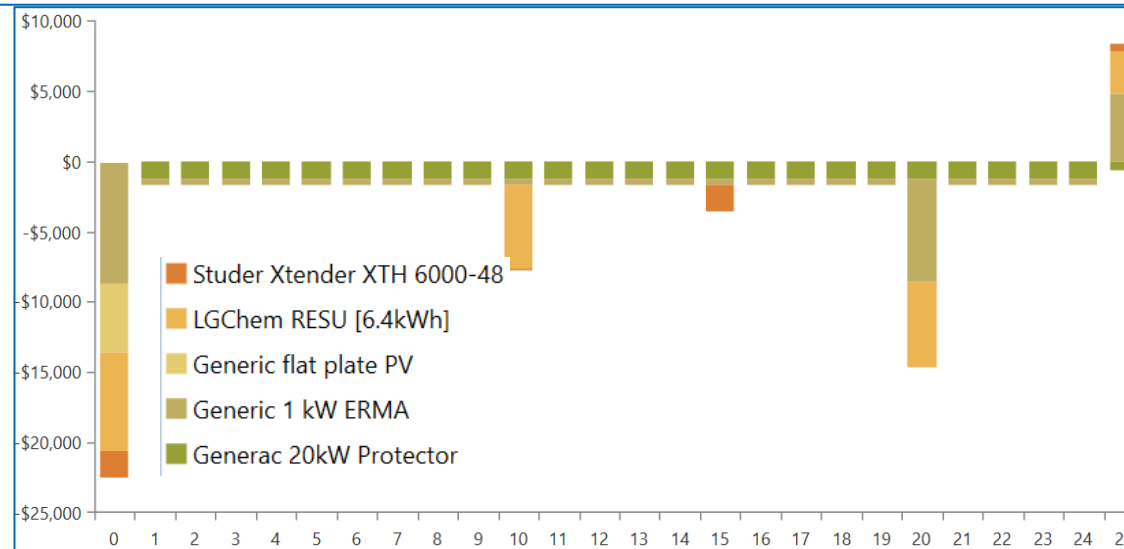

## Criteria to choose the optimum

- By default, NPC is used in HOMER Pro
  - Suggestion: analyze the results (not blind faith)
  - Check technical and physical viability
- Other criteria
  - Lowest O&M costs
  - Lowest fuel consumption
  - Highest RE percentage
  - Lowest emissions
  - ...

## 2.- Description of the Design Process

### c) Implementation guidelines



- Detailed Engineering Design Report
  - Civil engineering drawings
  - Detailed electrical drawings
  - Structural calculation note for the mounting structures.
  - Losses calculations due to obstacles.
- Some general guidelines, but the experienced installer will have to be the one who finally has knowledge of how to act in the different situations that arise in each installation
- Final site for the SWT may vary slightly, as a function of particular site conditions
- Foundation: the installer is responsible (part of the warranty)
- Construction plan
- Training plan (if any)
- O&M plan
- Lifting and/or lowering the SWT procedure
- Special care will be taken with the location of the dump load

# 3.- Specification, testing and commissioning, and O&M



- SWT
  - Norms to comply with
  - Documentation to submit
  - Technology specification
  - Installation requirements
- Technical room requirements
- Wind charge controller
  - Protection devices definition
  - Dump load specification
  - Compatibility
- Supporting structure
  - Requirements
  - Calculations
  - Height specification
- Control and monitoring
  - Parameters to measure and store
- Structural calculation note for the mounting structures.
- Losses calculations due to obstacles.
- Cable sizing calculations.
- Protection sizing calculations.
- The expected performance specifications.
- Details of procedures during construction works.
- Details of the equipment testing and testing procedures.
- Details of the plant commissioning test procedures.
- The complete manufacturer's documentation of the main components

# 3.- Specification, testing and commissioning, and O&M

- Civil engineering drawings, including at least:
  - SWT tower drawings, including all the necessary details for the proper installation, including the tower foundations.
  - Technical room drawings
- Detailed electrical drawings, including at least:
  - General SLD
  - Earthing diagram
  - Physical diagram of the wind turbine
  - The detailed diagram of the connections of the charge controllers

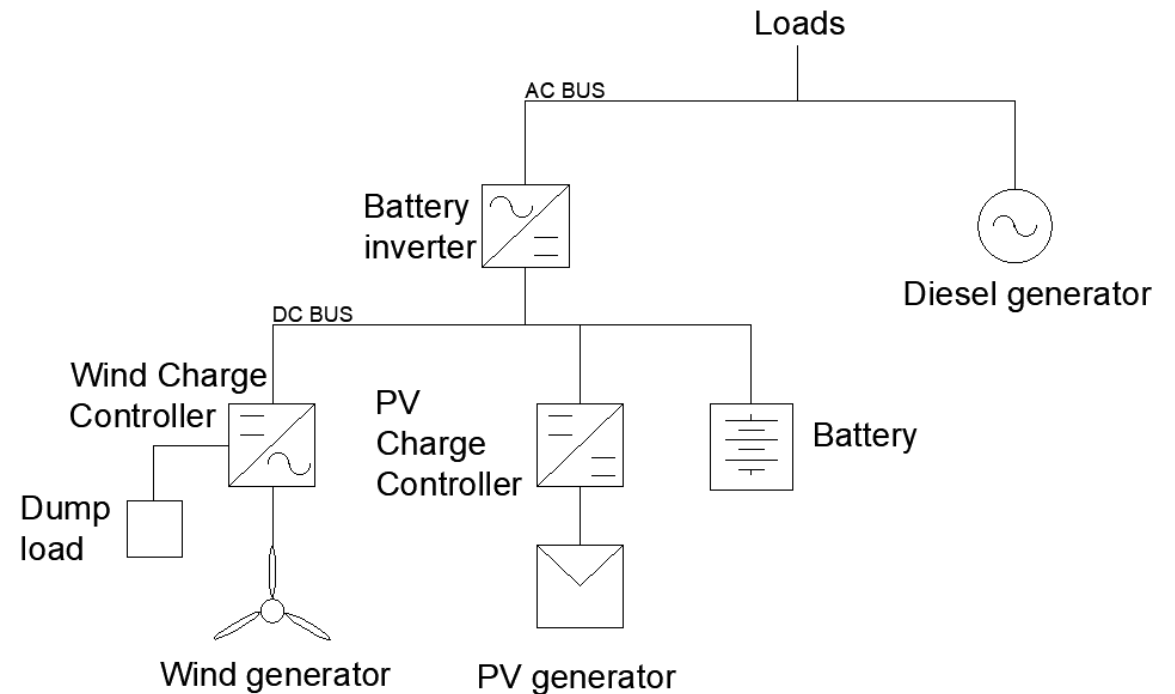

Simple SLDs of a DC-coupled Hybrid microgrid

# 3.- Specification, testing and commissioning, and O&M



## Testing and commissioning

- Acceptance protocol
- Inspection
  - Visual
  - Acoustic
  - Thermal
  - Electric
  - Mechanic
- Measurements
  - No-load measurements
  - Measurements under load
- Hand-over documents

## O&M

- General considerations
- Recommended procedures
  - Preventive maintenance: SWT, tower, documentation, charge controller
  - Corrective maintenance
  - Spare-parts management

Thank you very much